

EDS700ACBA  
13528287

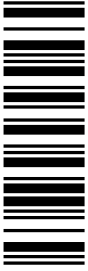

Translation **Hardware Manual**

# i700

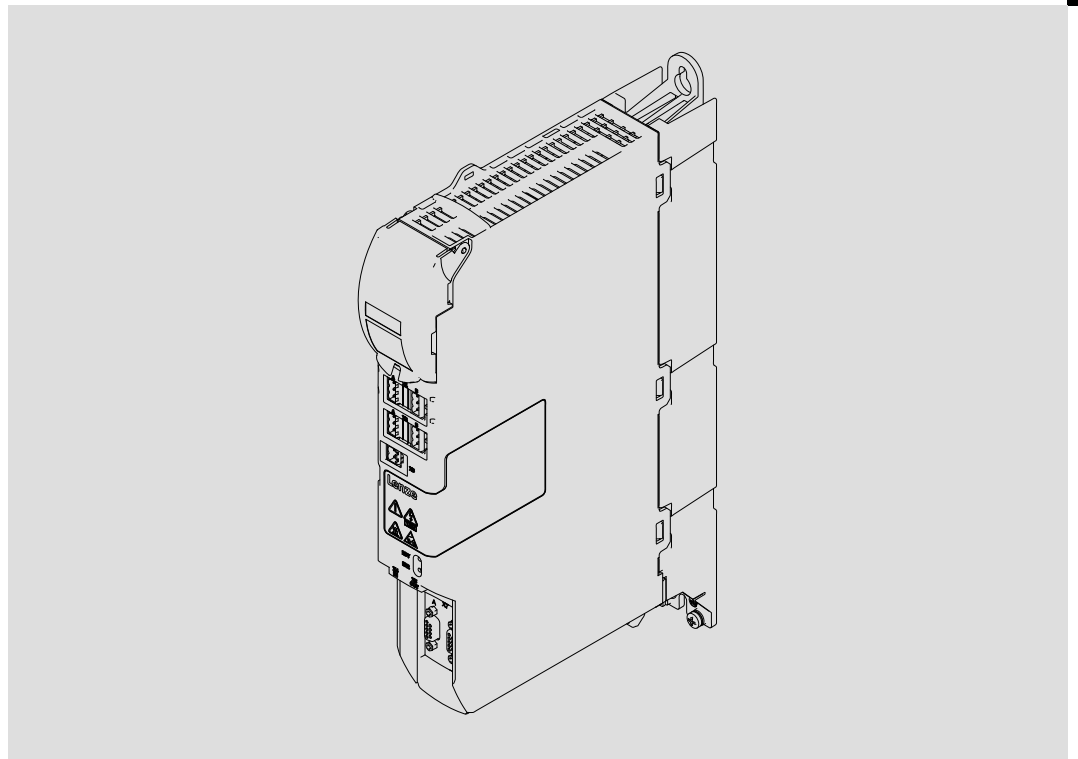

**E70AC...**

**Servo-Inverter i700**



<b>1</b>	<b>About this documentation</b> .....	<b>7</b>
1.1	Document history .....	7
1.2	Conventions used .....	8
1.3	Terms and abbreviations used .....	9
1.4	Notes used .....	12
<b>2</b>	<b>Safety instructions</b> .....	<b>13</b>
2.1	General safety and application notes for Lenze controllers .....	13
2.2	General safety and application notes for Lenze motors .....	16
2.3	Residual hazards .....	18
<b>3</b>	<b>Product description</b> .....	<b>20</b>
3.1	Device features .....	20
3.2	Overview of the devices .....	22
3.2.1	Supply modules .....	22
3.2.2	Axis modules .....	23
3.3	Identification .....	24
3.4	Product key .....	25
<b>4</b>	<b>Technical data</b> .....	<b>27</b>
4.1	General data and operating conditions .....	27
4.2	Rated data .....	31
4.2.1	External supply voltage 24 V .....	31
4.2.2	Busbar system for the DC bus .....	33
4.2.3	Supply modules .....	34
4.2.4	Axis modules .....	38
4.3	Overcurrent operation .....	42
4.3.1	Supply modules .....	44
4.3.2	Axis modules .....	44
4.4	Terminal description .....	45
4.4.1	Supply modules .....	45
4.4.2	Axis modules .....	51
<b>5</b>	<b>Mechanical installation</b> .....	<b>66</b>
5.1	Important notes .....	66
5.2	Drilling the holes into the mounting plate .....	67

5.3	Dimensions .....	68
5.3.1	Devices with standard built-in design .....	68
5.3.2	Assembly in standard built-in technique .....	69
5.3.3	Devices with "cold plate" design .....	70
5.3.4	Mounting in "cold plate" technique .....	71
5.3.5	Devices with push-through design .....	76
5.3.6	Assembly in push-through technique (thermal separation) .....	77
5.4	Notes on mounting the device version in push-through design .....	79
<b>6</b>	<b>Electrical installation .....</b>	<b>86</b>
6.1	Important notes .....	86
6.1.1	Electrical isolation .....	87
6.1.2	Device protection .....	87
6.1.3	Motor protection .....	88
6.1.4	Interaction with compensation equipment .....	88
6.2	Safety instructions for the installation according to UL/CSA .....	89
6.3	Installation according to EMC (installation of a CE-typical drive system) .....	93
6.3.1	Shielding .....	93
6.3.2	Mains connection, DC supply .....	95
6.3.3	Motor cable .....	96
6.3.4	Installation in the control cabinet .....	97
6.3.5	Wiring outside of the control cabinet .....	99
6.3.6	Detecting and eliminating EMC interferences .....	100
6.4	Measures when drive is used in IT systems .....	101
6.5	Preparations .....	103
6.5.1	Integrated PE conductor connection .....	103
6.5.2	Integrated DC bus connection .....	104
6.6	Power supply modules .....	105
6.7	Axis modules .....	107
<b>7</b>	<b>DC-bus operation .....</b>	<b>110</b>
7.1	Introduction .....	110
7.1.1	Terminology and abbreviations used .....	110
7.1.2	Advantages of a drive system .....	110
7.2	Conditions for trouble-free DC-bus operation .....	111
7.2.1	Voltages .....	111
7.2.2	Number of feeding points .....	111
7.2.3	Other conditions .....	111
7.3	DC-bus variants .....	112
7.3.1	Supply with one power supply module .....	112
7.3.2	Supply with power supply modules operated in parallel .....	113
7.3.3	Supply with regenerative power supply module .....	114

7.4	Rated data .....	115
7.4.1	General data .....	115
7.4.2	DC-supply power .....	115
7.4.3	DC-power requirements .....	117
7.5	Basic dimensioning .....	118
7.5.1	General information .....	118
7.5.2	Power distribution of controllers .....	119
7.5.3	Motor efficiency .....	120
7.5.4	Power loss of devices .....	120
7.5.5	Determining the power requirements .....	120
7.5.6	Determining the regenerative power requirements .....	120
7.5.7	Cable protection .....	120
7.6	Braking operation in a drive system .....	121
7.6.1	Basic considerations .....	121
7.7	EMC in DC-bus operation .....	122
7.7.1	Compliance with EMC category C3 (industrial premises) .....	122
7.7.2	Compliance with EMC category C2 (residential areas) .....	123
7.7.3	Assignment of filters .....	123
<b>8</b>	<b>Commissioning .....</b>	<b>125</b>
8.1	Before switching on .....	125
8.2	Quick commissioning .....	125
<b>9</b>	<b>Diagnostics .....</b>	<b>126</b>
9.1	Display of operating data, diagnostics .....	126
9.1.1	Supply modules .....	126
9.1.2	Axis modules .....	126
9.2	LED status displays .....	127
9.2.1	Supply modules .....	127
9.2.2	Axis modules .....	127
<b>10</b>	<b>Safety engineering .....</b>	<b>128</b>
10.1	Introduction .....	128
10.2	Important notes .....	129
10.2.1	Hazard and risk analysis .....	130
10.2.2	Standards .....	130
10.2.3	Mission time .....	131
10.3	Acceptance .....	132
10.3.1	Description .....	132
10.3.2	Periodic inspections .....	132
10.4	Certification .....	133
10.5	Basics for safety sensors .....	134

10.6	Basic Safety - STO .....	135
10.6.1	Mode of operation .....	135
10.6.2	Technical data .....	136
10.6.3	Electrical installation .....	138
<b>11</b>	<b>Accessories (overview) .....</b>	<b>139</b>
11.1	Overview .....	139
11.2	Mains chokes .....	140
11.3	RFI filter/mains filter .....	142
11.4	External brake resistors .....	143
11.5	Power supply units .....	144
11.6	Terminals .....	145
11.7	Components for operation in the DC-bus connection .....	154
11.8	Installation material for the push-through technique .....	155
11.9	EMC accessories .....	156
11.9.1	Shield mounting .....	156
<b>12</b>	<b>Appendix .....</b>	<b>158</b>
12.1	Total index .....	158

# 1 About this documentation

## Contents

The hardware manual contains the complete information required for the application as directed of the i700 series controllers and components.



### Tip!

Information and tools concerning the Lenze products can be found in the download area at [www.lenze.com](http://www.lenze.com)

## Validity

Type	Type designation	from hardware version	from software version
Power supply modules	E70ACPSE...	1x	-
Single axis modules	E70ACMxE...1...	1x	01.06
Double axis modules	E70ACMxE...2...	1x	01.06

## Target group

This hardware manual is intended for all persons who dimension, install, commission, and adjust drives of the i700 product series.

## 1.1 Document history

Material number	Version			Description
13528287	5.1	08/2018	TD15	General corrections and supplements: Data according to Dual-Use Regulation
13528287	5.0	05/2018	TD15	General corrections and supplements: "Extended Safety" version Data according to Dual-Use Regulation
13455352	4.0	05/2014	TD15	Supplements to the versions "Cold Plate" and "push-through design" UL notes in French
13445510	3.0	09/2013	TD15	General corrections and supplements New: UL approval
13432926	2.0	04/2013	TD15	General corrections New: encoder as sensor type
13412058	1.2	11/2012	TD15	1. Proof copy

# 1 About this documentation

## Conventions used

### 1.2 Conventions used

This documentation uses the following conventions to distinguish between different types of information:

#### Spelling of numbers

Decimal separator	Point	In general, the decimal point is used. For instance: 1234.56
-------------------	-------	---

#### Warnings

UL warnings		Given in English and French
UR warnings		

#### Text

Program name	» «	PC software For example: »Engineer«, »Global Drive Control« (GDC)
--------------	-----	--

#### Icons

Page reference		Reference to another page with additional information For instance:  16 = see page 16
Documentation reference		Reference to another documentation with additional information For example:  EDKxxx = see documentation EDKxxx

#### Parameter or object

Hexadecimal	0x1234	Refers to the parameter or object 1234
With colon	0x1234:5	Refers to the parameter or object 1234 with subindex 5

#### Parameter or object

Hexadecimal	0x1234	Refers to the parameter or object 1234
With colon	0x1234:5	Refers to the parameter or object 1234 with subindex 5



### 1.3 Terms and abbreviations used

#### General

Term	Description
Controllers Axis module Motor module	General designation for servo controllers and frequency inverters
Module	Electronic unit or device
Single axis module 1-axis module Single inverter	Controller for one motor / one drive axis
Double axis module 2-axis module Double inverter	Controller for two motors / two drive axes
Axis A Axis B	Designation of the first / second axis of double axis devices
Servo controller Servo inverter	Electronic controller for operating rotating field motors with variably adjustable speed and torque. "Servo" stands for especially dynamic drive characteristics.
i700, 9400, 9300	Lenze servo controller product series
Frequency inverter	Electronic controller for operating rotating field motors with variably adjustable speed and torque.
8400, 8200	Lenze frequency inverter product series
Power electronics	Rectification, DC bus and inverter
Control electronics	Open-loop control, closed-loop control, setpoint generation, monitoring
Power supply unit, Power supply module	Electronic rectifier unit with mains connection for supplying energy to the DC bus. In a DC-bus operation, the controllers are supplied via the DC bus.
DC-bus operation	Interconnection of several controllers and, if required, power supply modules on the DC-bus level
DC-bus level	Energy storage between rectification and DC-AC conversion, for one or more controllers

Term	Description
 EtherCAT	EtherCAT® is a real-time capable Ethernet system with a top performance. EtherCAT® is a registered trademark and patented technology, licensed by Beckhoff Automation GmbH, Germany.

Term	Description
$C_L$	Loading capacity for the 24 V supply
$f$	Frequency or frequency range
$f_{Ch}$	Switching frequency
$I_{aMx}$	Max. output current
$I_{aNdc}$	Rated value of continuous output current of the power supply module
$I_{aNx}$	Rated value of continuous output current, frequency-dependent
$I_{BRd}$	Continuous current RMS - important for the dimensioning of the cables
$I_{BRmax}$	Peak current
$I_{max\_3}$	Maximum short-time current after cycle time
$I_{max\_60}$	Maximum short-time current after cycle time
$I_{red\_12}$	Reduced current after cycle time (recovery phase)
$I_{red\_120}$	Reduced current after cycle time (recovery phase)
$I_{r4}$	Rated value of continuous output current at 4 kHz
$I_{r24}$	Rated current for the 24 V supply
$I_{max24}$	Maximum current for the 24 V supply
$P_{24}$	Rated power for the 24 V supply
$P_{Bd}$	Continuous braking power
$P_{loss}$	Power loss
$R_{Bmin}$	Nominal value of minimum brake resistance
$P_{BRmax}$	Peak braking power
$t_{fp}$	Maximum running time without initial load and compliance with the recovery time
$t_{on}$	Running time
$t_z$	Cycle time, periodic load change with running time and recovery time
$U_{Lrated}$	Rated mains voltage, also voltage range
$U_{DC}$	Rated DC bus voltage, also voltage range

### DC-bus operation

Term	Description
DC bus	The energy store in the controller or supply module from which the controller modulates the AC voltage for the motor. The DC buses of several controllers can be networked.
DC bus	Electrical connection of the DC connections of several controllers via cable or busbar.
DC-voltage level	DC-voltage level in the DC bus
Power supply module	Module with AC mains connection used to supply the DC bus of a drive system with DC voltage.
Regenerative power supply module	Power supply module with additional power regeneration into the AC mains
Multi-axis controllers (Multi Drive)	Controllers for connection to a DC bus. Multi-axis controllers have no AC mains connection and no brake chopper.
Single-axis controllers (Single Drive)	Controllers for connection to an AC mains or a DC bus. Single-axis controllers have an integrated brake chopper.
Brake chopper	Switching element in the controller used to dissipate excess energy in the DC bus via a brake resistor.
Brake resistor	High-performance resistor used to convert excess energy in the DC-bus into heat.
Braking operation	Motor operation in generator mode with energy feedback from the motor to the controller.

### Integrated safety engineering

Term	Description
STO	Functional safety: <i>safe torque off</i>
Mission time	Restricted period of use of safety-related components
Proof test interval	Period after which an examination must be performed to reveal undetected errors.

# 1 About this documentation

## Notes used

### 1.4 Notes used

The following pictographs and signal words are used in this documentation to indicate dangers and important information:

#### Safety instructions

Structure of safety instructions:





#### **Danger!**



(characterises the type and severity of danger)

#### **Note**



(describes the danger and gives information about how to prevent dangerous situations)

Pictograph and signal word	Meaning
 <b>Danger!</b>	<b>Danger of personal injury through dangerous electrical voltage.</b> Reference to an imminent danger that may result in death or serious personal injury if the corresponding measures are not taken.
 <b>Danger!</b>	<b>Danger of personal injury through a general source of danger.</b> Reference to an imminent danger that may result in death or serious personal injury if the corresponding measures are not taken.
 <b>Stop!</b>	<b>Danger of property damage.</b> Reference to a possible danger that may result in property damage if the corresponding measures are not taken.

#### Application notes

Pictograph and signal word	Meaning
 <b>Note!</b>	Important note to ensure troublefree operation
 <b>Tip!</b>	Useful tip for simple handling
	Reference to another documentation

#### Special safety instructions and application notes

Pictograph and signal word	Meaning
 <b>Warnings!</b>	<b>Safety note or application note for the operation according to UL or CSA requirements.</b>
 <b>Warnings!</b>	The measures are required to meet the requirements according to UL or CSA.

## 2 Safety instructions

### 2.1 General safety and application notes for Lenze controllers

(in accordance with Low-Voltage Directive 2014/35/EU)

#### For your personal safety

Disregarding the following basic safety measures may lead to severe personal injury and damage to material assets:

- ▶ Only use the product as directed.
- ▶ Never commission the product in the event of visible damage.
- ▶ Never commission the product before assembly has been completed.
- ▶ Do not carry out any technical changes on the product.
- ▶ Only use the accessories approved for the product.
- ▶ Only use original spare parts from Lenze.
- ▶ Observe all regulations for the prevention of accidents, directives and laws applicable on site.
- ▶ Transport, installation, commissioning and maintenance work must only be carried out by qualified personnel.
  - IEC 364 and CENELEC HD 384 or DIN VDE 0100 and IEC-Report 664 or DIN VDE 0110 and national regulations for the prevention of accidents must be observed.
  - According to the basic safety information, qualified, skilled personnel are persons who are familiar with the assembly, installation, commissioning, and operation of the product and who have the qualifications necessary for their occupation.
- ▶ Observe all specifications in this documentation.
  - This is the condition for safe and trouble-free operation and the achievement of the specified product features.
  - The procedural notes and circuit details described in this documentation are only proposals. It's up to the user to check whether they can be transferred to the particular applications. Lenze Automation GmbH does not accept any liability for the suitability of the procedures and circuit proposals described.
- ▶ According to their enclosure, Lenze controllers (frequency inverters, servo inverters, DC speed controllers) and their components can carry a voltage, or parts of the controllers can move or rotate during operation. Surfaces can be hot.
  - Non-authorized removal of the required cover, inappropriate use, incorrect installation or operation create the risk of severe injury to persons or damage to material assets.
  - For more information, please see the documentation.
- ▶ There is a high amount of energy within the controller. Therefore always wear personal protective equipment (body protection, headgear, eye protection, ear protection, hand guard) when working on the controller when it is live.

**Intended use**

Drive controllers are components designed for the installation in electrical systems or machinery. They must not be used as household appliances. They are intended exclusively for professional and commercial purposes according to EN 61000-3-2.

When controllers are installed into machines, commissioning (i.e. starting of the operation as directed) is prohibited until it is proven that the machine complies with the regulations of the EC Directive 2006/42/EC (Machinery Directive); EN 60204 must be observed.

Commissioning (i.e. starting of the operation as directed) is only allowed when there is compliance with the EMC Directive (2014/30/EU).

The inverters meet the requirements of the Low-Voltage Directive 2014/35/EU. The harmonised standard EN 61800-5-1 applies to the inverters.

The technical data and supply conditions can be obtained from the nameplate and the documentation. They must be strictly observed.

The actuation of the inverters in specific areas in compliance with EN61800-3 (EMC categories) possibly requires the use of filters.

**Warning:** in residential environments, this product may cause high-frequency interferences which may make the implementation of interference suppression measures necessary.

**Transport, storage**

Please observe the notes on transport, storage, and appropriate handling.

Observe the climatic conditions according to the technical data.

**Installation**

The controllers must be installed and cooled according to the instructions given in the corresponding documentation.

The ambient air must not exceed degree of pollution 2 according to EN 61800-5-1.

Ensure proper handling and avoid mechanical stress. Do not bend any components and do not change any insulation distances during transport or handling. Do not touch any electronic components or contacts.

Controllers contain electrostatically sensitive components which can easily be damaged by inappropriate handling. Do not damage or destroy any electrical component since doing so might endanger your health!

### Electrical connection

When working on live inverters, observe the applicable national regulations for the prevention of accidents.

Carry out the electrical installation according to the relevant regulations (e. g. cable cross-sections, fusing, connection to the PE conductor). Additional notes are included in the documentation.

This documentation contains information on installation in compliance with EMC (shielding, earthing, filter, and cables). These notes must also be observed for CE-marked controllers. The manufacturer of the system is responsible for compliance with the limit values demanded by EMC legislation. The controllers must be installed in housings (e.g. control cabinets) to meet the limit values for radio interferences valid at the site of installation. The housings must enable an EMC-compliant installation. Observe in particular that e.g. the control cabinet doors have a circumferential metal connection to the housing. Reduce housing openings and cutouts to a minimum.

Lenze controllers may cause a DC current in the PE conductor. If a residual current device (RCD) is used for protection against direct or indirect contact for a controller with three-phase supply, only a residual current device (RCD) of type B is permissible on the supply side of the controller. If the controller has a single-phase supply, a residual current device (RCD) of type A is also permissible. Apart from using a residual current device (RCD), other protective measures can be taken as well, e.g. electrical isolation by double or reinforced insulation or isolation from the supply system by means of a transformer.

### Operation

If necessary, systems including controllers must be equipped with additional monitoring and protection devices according to the valid safety regulations (e.g. law on technical equipment, regulations for the prevention of accidents). You are allowed to adapt the controllers to your application. Please observe the corresponding information given in the documentation.

After the controller has been disconnected from the supply voltage, all live components and power terminals must not be touched immediately because capacitors can still be charged. Please observe the corresponding stickers on the controller.

Keep all protective covers and doors closed during operation.

### Safety functions

Certain controller versions support safety functions (e.g. "Safe torque off", formerly "Safe standstill") according to the requirements of the EC Directive 2006/42/EC (Machinery Directive). The notes on the integrated safety system provided in this documentation must be observed.

### Maintenance and servicing

The controllers do not require any maintenance if the prescribed conditions of operation are observed.

**Waste disposal**

Recycle metal and plastic materials. Assembled PCBs must be disposed of professionally.

**The product-specific safety and application notes given in these instructions must be observed!**

**2.2 General safety and application notes for Lenze motors**

(according to Low-Voltage Directive 2014/35/EU)

**General**

Low-voltage machines have dangerous, live and rotating parts as well as possibly hot surfaces.

Synchronous machines induce voltages at open terminals during operation.

All operations serving transport, connection, commissioning and maintenance are to be carried out by skilled, responsible technical personnel (observe EN 50110-1 (VDE 0105-1) and IEC 60364). Improper handling can cause severe injuries or damages.

Lowvoltage machines may only be operated under the conditions that are indicated in the section "Application as directed".

The conditions at the place of installation must comply with the data given on the nameplate and in the documentation.

**Application as directed**

Lowvoltage machines are intended for commercial installations. They comply with the harmonised standards of the series IEC/EN 60034 (VDE 0530). Their use in potentially explosive atmospheres is prohibited unless they are expressly intended for such use (follow additional instructions).

Lowvoltage machines are components for installation into machines as defined in the Machinery Directive 2006/42/EC. Commissioning is prohibited until the conformity of the end product with this directive has been established (follow i. a. EN 60204-1).

Lowvoltage machines with IP23 protection or less are only intended for outdoor use when applying special protective features.

The integrated brakes must not be used as safety brakes. It cannot be ruled out that factors which cannot be influenced, such as oil ingress due to a defective Aside shaft seal, cause a brake torque reduction.

**Transport, storage**

Damages must be reported immediately upon receipt to the forwarder; if required, commissioning must be excluded. Tighten screwed in ring bolts before transport. They are designed for the weight of the lowvoltage machines, do not apply extra loads. If necessary, use suitable and adequately dimensioned means of transport (e. g. rope guides).

Remove transport locking devices before commissioning. Reuse them for further transport. When storing low-voltage machines, ensure a dry, dustfree and low-vibration ( $v_{\text{eff}} \leq 0.2 \text{ mm/s}$ ) environment (bearing damage while being stored).



### Installation

Ensure an even surface, solid foot/flange mounting and exact alignment if a direct clutch is connected. Avoid resonances with the rotational frequency and double mains frequency which may be caused by the assembly. Turn rotor by hand, listen for unusual slipping noises. Check the direction of rotation when the clutch is not active (observe section "Electrical connection").

Use appropriate means to mount or remove belt pulleys and clutches (heating) and cover them with a touch guard. Avoid impermissible belt tensions.

The machines are halfkey balanced. The clutch must be halfkey balanced, too. The visible jutting out part of the key must be removed.

If required, provide pipe connections. Designs with shaft end at bottom must be protected with a cover which prevents the ingress of foreign particles into the fan. Free circulation of the cooling air must be ensured. The exhaust air also the exhaust air of other machines next to the drive system must not be taken in immediately.

### Electrical connection

All operations must only be carried out by qualified and skilled personnel on the lowvoltage machine at standstill and deenergised and provided with a safe guard to prevent an unintentional restart. This also applies to auxiliary circuits (e. g. brake, encoder, blower).

Check safe isolation from supply!

If the tolerances specified in EN 600341; IEC 34 (VDE 05301) voltage  $\pm 5\%$ , frequency  $\pm 2\%$ , waveform, symmetry are exceeded, more heat will be generated and the electromagnetic compatibility will be affected.

Observe the data on the nameplate, operating notes, and the connection diagram in the terminal box.

The connection must ensure a continuous and safe electrical supply (no loose wire ends); use appropriate cable terminals. The connection to the PE conductor must be safe. The plug-in connectors must be bolted tightly (tostop).

The clearances between blank, live parts and to earth must not fall below 8 mm at  $V_{\text{rated}} \leq 550\text{ V}$ , 10 mm at  $V_{\text{rated}} \leq 725\text{ V}$ , 14 mm at  $V_{\text{rated}} \leq 1000\text{ V}$ .

The terminal box must be free of foreign particles, dirt and moisture. All unused cable entries and the box itself must be sealed against dust and water.

**Commissioning and operation**

Before commissioning after longer storage periods, measure insulation resistance. In case of values  $\leq 1 \text{ k}\Omega$  per volt of rated voltage, dry winding.

For trial run without output elements, lock the featherkey. Do not deactivate the protective devices, not even in a trial run.

Check the correct operation of the brake before commissioning lowvoltage machines with brakes.

Integrated thermal detectors do not provide full protection for the machine. If necessary, limit the maximum current. Parameterise the controller so that the motor will be switched off with  $I > I_{\text{rated}}$  after a few seconds of operation, especially at the risk of blocking.

Vibrational severities  $v_{\text{eff}} \leq 3.5 \text{ mm/s}$  ( $P_{\text{rated}} \leq 15 \text{ kW}$ ) or  $4.5 \text{ mm/s}$  ( $P_{\text{rated}} > 15 \text{ kW}$ ) are acceptable if the clutch is activated.

If deviations from normal operation occur, e.g. increased temperatures, noises, vibrations, find the cause and, if required, contact the manufacturer. In case of doubt, switch off the lowvoltage machine.

If the machine is exposed to dirt, clean the air paths regularly.

Shaft sealing rings and roller bearings have a limited service life.

Regrease bearings with relubricating devices while the lowvoltage machine is running. Only use the grease recommended by the manufacturer. If the grease drain holes are sealed with a plug, (IP54 drive end; IP23 drive and nondrive end), remove plug before commissioning. Seal bore holes with grease. Replace prelubricated bearings (2Z bearing) after approx. 10,000 h 20,000 h, at the latest however after 3 4 years.

**The product-specific safety and application notes given in these instructions must be observed!!**

**2.3****Residual hazards****Protection of persons**

- ▶ Before working on the controller, check whether all power terminals are deenergised because
  - depending on the controller - the power terminals U, V, W, +UG, -UG, Rb1, and Rb2 carry hazardous voltages for up to 3 to 30 minutes after power-off.
  - the power terminals L1, L2, L3; U, V, W, +UG, -UG, Rb1 and Rb2 carry hazardous voltages when the motor is stopped.

**Device protection**

- ▶ Connect/disconnect all pluggable terminals only in deenergised condition!
- ▶ Detach the controllers from the installation, e.g. from the rear panel of the control cabinet, only in deenergised condition!

### **Motor protection**

- ▶ Depending on the controller settings, the connected motor can be overheated by:
  - For instance, longer DC-braking operations.
  - Longer operation of self-ventilated motors at low speed.

### **Protection of the machine/system**

- ▶ Drives can reach dangerous overspeeds (e.g. setting of high output frequencies in connection with motors and machines unsuitable for such conditions):
  - The controllers do not offer any protection against such operating conditions. Use additional components for this purpose.
- ▶ Switch **contactors in the motor cable** only if the controller is inhibited.  
When switching contactors in the motor cable while the controller is enabled, you can activate monitoring functions of the controller. If no monitoring function is activated, switching is permissible.

### **Parameter set transfer**

- ▶ During the parameter set transfer (initialisation), no undefined states occur.
  - Additional measures for the protection of the device or for the prevention of unrequested and/or non-braking motor movements are not required.
- ▶ If no data for the initialisation are transmitted by the L-force Controller, the i700 servo inverter uses the "Lenze setting" for the parameters.

### 3 Product description

#### Device features

### 3 Product description

#### 3.1 Device features

Features	Power supply modules	Single axis module	Double axis module
Central mains connection	✓	-	-
Can be connected in parallel	✓	-	-
Integrated brake chopper	✓	-	-
Direct side-by-side mounting	✓	✓	✓
Mechanical design (alternative)			
Built-in unit	✓	✓	✓
Push-through technique	✓	✓	✓
Cold plate	✓	✓	✓
DC-bus wiring			
Integrated	✓	✓	✓
Option: via cable	✓	✓	✓
Terminals in separate accessory kits	✓	✓	✓
Communication			
EtherCAT®	-	✓	✓
Touch probe inputs	-	2	2 x 2
Suitable motors			
ASM	-	✓	✓
SM	-	✓	✓
Integrated motor holding brake control			
Automatically	-	✓	✓
Via the control system	-	✓	✓
Servo control feedback system (alternative)			
Resolver	-	✓	✓
SinCos encoder	-	✓	✓
Operating modes			
Velocity mode	-	✓	✓
Cyclic synchronous velocity mode	-	✓	✓
Cyclic synchronous position mode	-	✓	✓
Cyclic synchronous torque mode	-	✓	✓
Integrated safety system (STO)	-	✓	✓

**Additional information on export control**

By limiting the maximum output frequency to 599 Hz, the devices are not subject to the export restrictions of the "EC-Dual-Use Regulation" - EC 428/2009.

This applies to devices with the product key E70ACMDxxxx4xxxxxx. The maximally possible output frequency is given on the nameplate.

Certain applications allow the devices E70ACMSxxxx4xxxxxx to be supplied with the previous maximum output frequency. If needed, get in touch with your Lenze contact person.

### 3 Product description

Overview of the devices  
Supply modules

#### 3.2 Overview of the devices

##### 3.2.1 Supply modules

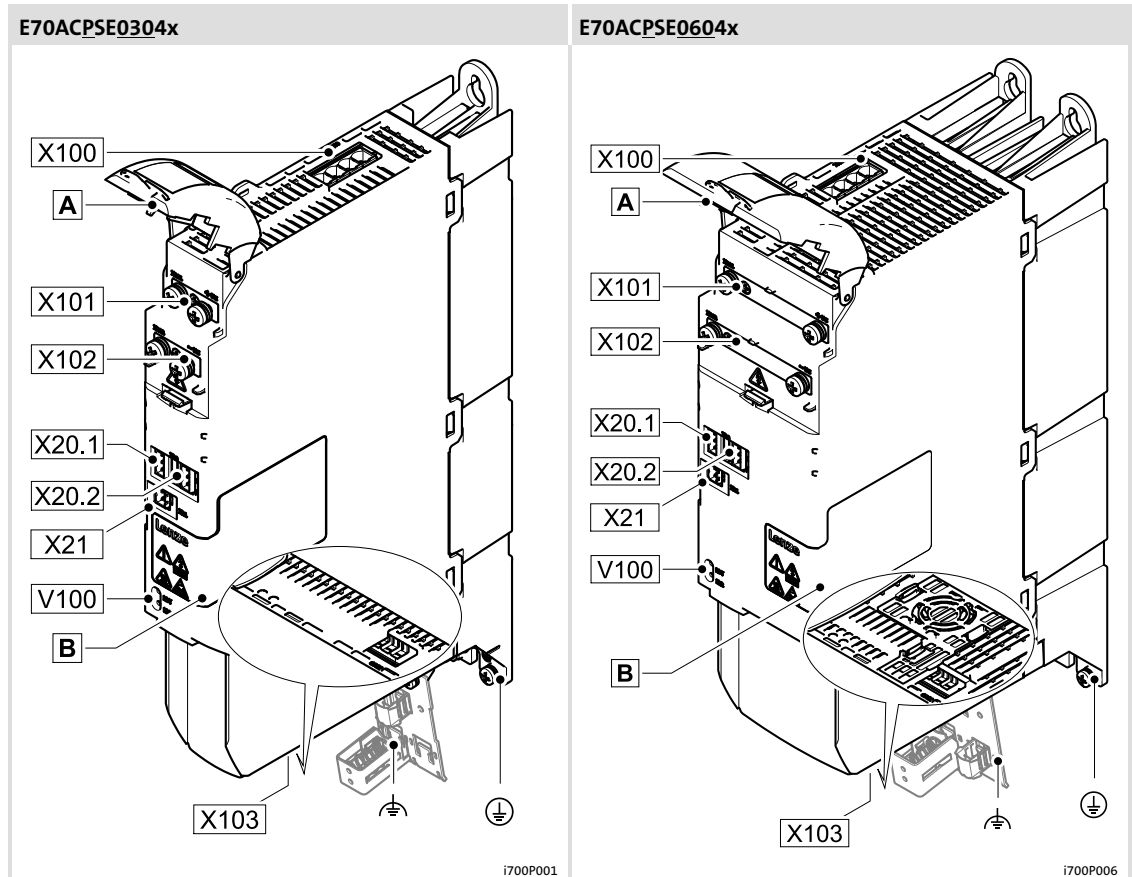

Connections and elements		Info
▣	Hinged cover of DC-bus connections	49
▣	Nameplate and warning symbols	24
X20.1	Digital inputs, digital outputs	47
X20.2		
X21	External 24-V supply	46
X100	Mains connection	48
X101	DC-bus UG+	49
X102	DC-bus UG-	
X103	Connection of brake resistor	50
V100	LED status display	127
⊕	PE conductor	103
⏏	Shield connection (functional earth)	103

3.2.2 Axis modules

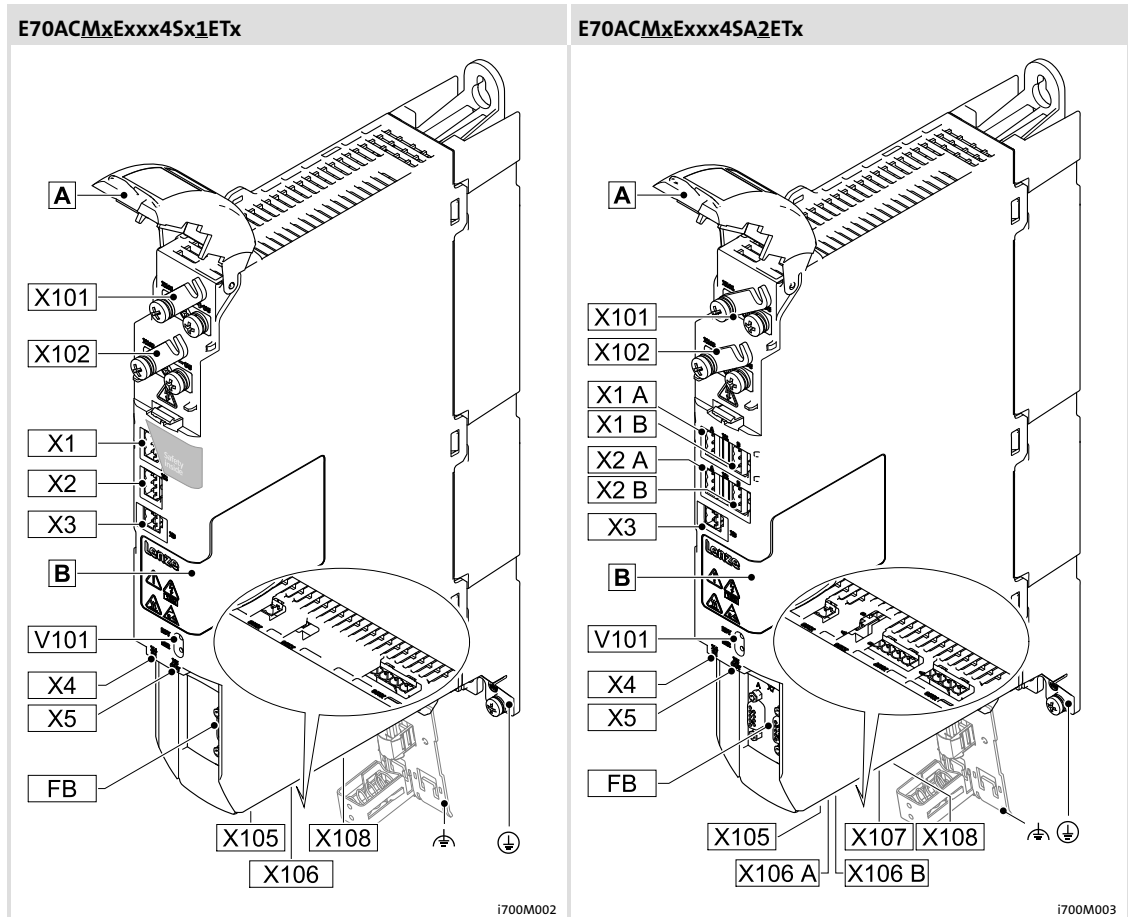

Connections and elements		Info
A	Hinged cover of DC-bus connections	49
B	Nameplate and warning symbols	24
V101	LED status display	127
X1 A/B	Integrated safety system	128
X2 A/B	Touch probe	53
X3	External 24-V supply	54
X4	EtherCAT IN	55
X5	EtherCAT OUT	
FB	Servo control feedback system (alternative)	
	X7 A/B - Resolver (E70ACM...R)	57
	X8 A/B - Encoder (E70ACM...E)	59
X101	DC-bus UG+	61
X102	DC-bus UG-	
X105	24-V supply of motor holding brake	62
X106 A/B	Motor holding brake	63
X107	Motor - axis B	64
X108	Motor - axis A	
⊕	PE conductor	103
⊕	Shield connection (functional earth)	103

### 3 Product description Identification

#### 3.3 Identification

The type data used in this manual refer to the nameplate which is placed at the front of the controller (Fig. 3-1).

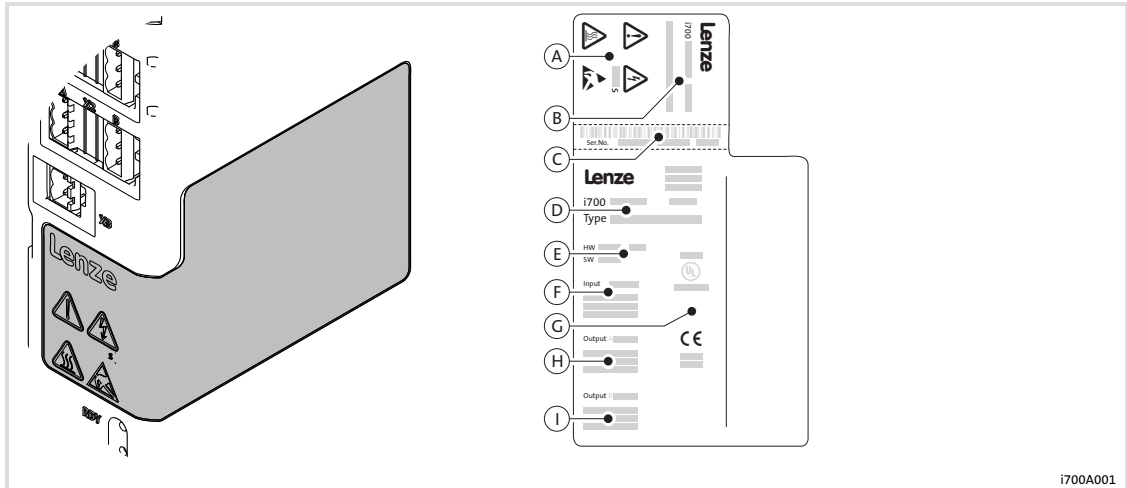

Fig. 3-1 Contents and position of the nameplate

- A Notes and warning symbols ☐
- B Product designation at the front
- C Serial number
- D Product designation at the side
- E Hardware and/or software version
- F Rated input power
- G Conformity and approval identification
- H Rated output power (power supply module or motor (A))
- I Rated output power (for 2-axis modules: motor B)

☐	Icon	Description
		<b>Long discharge time:</b> All power terminals remain live for a few minutes after mains disconnection! The duration is given under the warning symbol on the device.
		<b>High leakage current:</b> Carry out fixed installation and PE connection according to EN 61800-5-1!
		<b>Electrostatic sensitive devices:</b> Before working on the device, the personnel must be free of electrostatic charge!
		<b>Hot surface:</b> Risk of burns! Hot surfaces should not be touched without wearing protective gloves.



3.4 Product key

	1...4	5	6	7	8	9...11	12	13	14	15	16,17	18
<b>Power supply</b>	E70A	C	P	S	x	xxx	4	x				
<b>Servo inverter</b>	E70A	C	M	x	x	xxx	4	x	x	x	xx	x
<b>Product series</b> Servo inverter i700												
<b>Mounting type</b> C = control cabinet												
<b>Version</b> M = axis module (servo inverter) P = power supply module												
<b>Version</b> D = < 599 Hz S = > 599 Hz or standard												
<b>Mounting type</b> E = built-in technique D = push-through technique C = cold plate technique												
<b>Output current e.g.</b> 005 = 5 A 060 = 60 A												
<b>Voltage class</b> 4 = 400/480 V, 3/PE AC												
<b>Ambient conditions</b> S = standard industrial environment IE33 according to IEC 60721-3-3 V = rough environment (coated printed circuit boards)												
<b>Safety system</b> A = with integrated safety engineering "Basic Safety - STO" B = with integrated safety engineering "Extended Safety"												
<b>Number of axes</b> 1 = single axis module (single inverter) 2 = double axis module (double inverter)												
<b>Communication</b> ET = EtherCAT®												
<b>Type of encoder</b> R = resolver E = SinCos encoder												

The nameplate serves to identify delivered products by nameplate data. The product catalogue provides information on the possible configuration to order the products.

**Tip!**

Depending on the topic, the type designation parts important for the identification are underlined, e.g. E70ACMxD0054Sx1xxx.

## 4 Technical data

### 4.1 General data and operating conditions

Conformity and approval			
Conformity			
CE	2006/95/EC	Low-Voltage Directive	
	2004/108/EC	EMC Directive	
Machinery Directive	2006/42/EC	Logic unit to ensure safety functions (safety component acc. to Machinery Directive)	
EAC	TP TC 004/2011 (TR CU 004/2011)	On safety of low voltage equipment	Eurasian Conformity TR CU: Technical Regulation of Customs Union
	TP TC 020/2011 (TR CU 020/2011)	Electromagnetic compatibility of technical means	
Approval			
cUL <sub>US</sub>	UL 508C	E70ACxSE...	Industrial Control Equipment, Lenze File No. E132659
cUR <sub>US</sub>	CSA 22.2 No. 14	E70ACxSC... E70ACxSD...	
Protection of persons and devices			
Enclosure	EN 60529	IP 20	Specification <ul style="list-style-type: none"> <li>• applies to the fully assembled state ready for use</li> <li>• does not apply to the wire range of the terminals</li> </ul>
	UL	Protection against contact in accordance with Open Type	
	EN 60529	Mounting type "push-through technique", heatsink side: <ul style="list-style-type: none"> <li>• IP54</li> </ul>	
Insulation resistance	EN 61800-5-1	< 2000 m amsl: overvoltage category III > 2000 m amsl: overvoltage category II	
Insulation of control circuits	EN 61800-5-1	Safe mains isolation through double/reinforced insulation (☐ 6.1.1): <ul style="list-style-type: none"> <li>• Touch probe inputs</li> <li>• Safety system inputs</li> <li>• Encoder feedback (☐ 56)</li> </ul>	
Short-circuit strength	EN 61800-5-1	<ul style="list-style-type: none"> <li>• Motor connection: limited, controller is inhibited, error acknowledgement is required</li> <li>• Brake control: limited, error acknowledgement is required</li> <li>• Control electronics and holding brake supply connections: not short-circuit-proof</li> </ul>	
Protective measures integrated for		<ul style="list-style-type: none"> <li>• Short circuit</li> <li>• Earth fault</li> <li>• Overvoltage</li> <li>• Motor overload (temperature detection via encoder, I<sup>2</sup>t monitoring)</li> </ul>	
Contact current	EN 61800-5-1	> 3.5 mA AC, > 10 mA DC	Observe the regulations and safety instructions!
mains switching		Cyclic mains switching of 5 times in 5 minutes is permissible without restrictions.	
Starting current		≤ 2 x I <sub>rated</sub>	
Discharge time of charge stored after mains disconnection		typically 5 min The duration is indicated by a warning symbol on the device.	

EMC		
Operation in industrial environment	EN 61000-3	The devices are intended for use in an industrial environment. A drive system consisting of a power supply module and 6 axis modules (each with a motor cable length of 25m) complies with EMC class „C3“ without any external measures. When third party power supply modules, power supply modules connected in parallel or longer motor cable lengths are used, matching mains filters must be installed to comply with the EMC requirements.
		The compliance with the requirements for the machine/plant is the responsibility of the manufacturer of the machine or system!
Operation on public supply systems	EN 61000-3	When being used on public network, additional measures must be taken to limit the expected radio interference.
Noise emission		
Cable-guided	EN 61800-3	Depending on the filter at the central power supply module
Radiation	EN 61800-3	Single components of the i700 series: ● Category C3
Noise immunity (according to requirements of EN 61800-3)		
Electrostatic discharge (ESD)	EN 61000-4-2	8 kV for air discharge to control cabinet, 4 kV for contact discharge to housing
Radio frequency		
Cable-guided	EN 61000-4-6	150 kHz ... 80 MHz, 10 V/m 80 % AM (1kHz)
Interference (housing)	EN 61000-4-3	80 MHz ... 1000 MHz, 10 V/m 80 % AM (1kHz) 1.4 GHz ... 2 GHz, 3 V/m 80 % AM (1kHz) 2 GHz ... 2.7 GHz, 1 V/m 80 % AM (1kHz)
Burst		
Power terminals and interfaces	EN 61000-4-4	2 kV/5 kHz
Signal interfaces	EN 61000-4-4	1 kV/5 kHz
Control terminals	EN 61000-4-4	2 kV/5 kHz
Surge		
Power terminals	EN 61000-4-5	1.2/50 $\mu$ s, 1 kV phase/phase, 2 kV phase/PE
Control terminals	EN 61000-4-5	1.2/50 $\mu$ s, 1 kV

Environmental conditions			
Climate			
Storage	IEC/EN 60721-3-1	1K3 (-25 ... +60 °C)	< 6 months
		1K3 (-25 ... +40 °C)	> 6 months
Transport	IEC/EN 60721-3-2	2K3 (-25 ... +70 °C)	
Operation	IEC/EN 60721-3-3	3K3 (-10 ... +55 °C) For operation above +40 °C: <ul style="list-style-type: none"> <li>● Reduce rated output current by 2.5 %/°C</li> </ul>	
Site altitude		0 ... 4000 m amsl 1000 ... 4000 m amsl: <ul style="list-style-type: none"> <li>● Reduce rated output current by 5 %/1000 m</li> </ul>	
Pollution	EN 61800-5-1	Pollution degree 2	
Vibration resistance (9.81 m/s <sup>2</sup> = 1 g)			
Transport	EN 60721-3-2	2M2 2 ... 9 Hz: amplitude 3.5 mm 10 ... 200 Hz: acceleration resistant up to 10 m/s <sup>2</sup> 200 ... 500 Hz: acceleration resistant up to 15 m/s <sup>2</sup>	
Operation	EN 61800-5-1	10 ... 57 Hz: amplitude 0.075 mm 57 ... 150 Hz: acceleration resistant up to 10 m/s <sup>2</sup>	
	Germanischer Lloyd	general vibration stress characteristic 1 5 ... 13.2 Hz: amplitude ±1 mm 13.2 ... 100 Hz: acceleration resistant up to 0.7 g	

Supply conditions		
<b>Power supply modules</b>		
AC mains connection		Direct connection to an AC system acc. to technical data
Power systems		
TT		With earthed neutral:
TN		<ul style="list-style-type: none"> <li>Operation permitted without restrictions.</li> </ul>
IT		When appropriate measures are taken on the power supply module, the operation in IT systems is permissible (☐ 101). <ul style="list-style-type: none"> <li>Connect isolating transformer upstream</li> <li>Separate internal EMC filters from earth connection</li> </ul>
Operation on public supply systems	EN 61000-3-2	Measures for the limitation of harmonic currents at a total power on the mains > 1 kW: <ul style="list-style-type: none"> <li>Operation without additional measures</li> </ul>
	EN 61000-3-12	from a mains current > 16 A: <ul style="list-style-type: none"> <li>connect assigned mains choke upstream</li> <li>Observe <math>R_{sce} \geq 350</math></li> </ul>
		$R_{sce}$ : Ratio of short circuit power at the connection point of the machine/system to the public network The compliance with the requirements for the multi-axis grouping with power supply module and for the machine/plant is the responsibility of the manufacturer of the machine or plant.
<b>Axis modules</b>		
DC system connection		Direct connection to a DC system acc. to technical data <ul style="list-style-type: none"> <li>E70ACP... power supply modules</li> <li>Equivalent DC sources acc. to technical data</li> </ul>
		DC voltage symmetrical to PE required. Earthing of +UG/-UG conductor will destroy the axis modules.
<b>Motors</b>		Only use motors suitable for inverter operation. L-force motors from Lenze meet the requirements.
Motor cable length		≤ 50 m
Encoder cable length		≤ 50 m
<b>Requirements on the motor cable</b>		
Capacitance per unit length		
≤ 2.5 mm <sup>2</sup> /AWG 14		$C_{Core/core}/C_{Core/shield} < 75/150$ pF/m
≥ 4 mm <sup>2</sup> /AWG 12		$C_{Core/core}/C_{Core/shield} < 150/300$ pF/m
Electric strength		
	VDE 0250-1	$U_0/U = 0.6/1.0$ kV ( $U_0$ = r.m.s. value external - conductor/PE, $U$ = r.m.s. value - external conductor/external conductor)
	UL	$U \geq 600$ V ( $U$ = r.m.s. value external conductor/external conductor)
<b>Mounting conditions</b>		
Mounting place		In the control cabinet
Mounting position		Vertical
Free space		
At the top/at the bottom		≥ 80 mm / ≥ 120 mm
On the sides		Side-by-side mounting without any clearance
		Observe the device-related notes on mounting.

4.2 Rated data

4.2.1 External supply voltage 24 V

The control electronics of the devices must be supplied from an external 24 V voltage source. In order to ensure that the control electronics will still work during mains failure (on the power side), the 24 V supply should be independent of this system, if possible, e.g. by means of a separate system, backup supply via battery, or DC supply.

The supply voltage terminal is designed to be wired from one device to another (loop-through connection). The number of devices to be supplied by loop-through is limited by the maximum current of the terminal.

Requirements for the 24 V voltage supply:

Electrical data		
Rated voltage	24 V	In accordance with IEC 61131-2
Voltage range	19.2 ... 28.8 V	
Residual ripple	Max. ± 5 %	
Safe separation	SELV or PELV	
Looping through	Max. 16 A with 2.5 mm <sup>2</sup> Max. 10 A with 1.5 mm <sup>2</sup>	
Cable protection	Circuit breaker with tripping characteristic B or C Standard blade-type fuses	≤ 20 A, ≥ 30 V

The 24 V voltage source must at least provide the total current of all devices supplied. The increased current  $I_{\max 24}$  is required when the internal fans are connected. It may take up to 0.5 s until the fans have accelerated. The 24 V voltage source must be able to also provide the required power in the case of undervoltage.

Current consumption of the devices from the 24 V voltage supply:

	$I_{r24}$	$P_{24}$	$I_{max24}$	$C_L$	Terminal
	[A]	[W]	[A]	[ $\mu$ F]	
E70ACPSx0304x	0.5	12	1.5	500	X21
E70ACPSx0604x	0.5	12	1.5		
E70ACMxx0054xx1xxx	0.5	12	1.0	3000	X3
E70ACMxx0104xx1xxx	0.6	14	1.0		
E70ACMxx0204xx1xxx	0.6	14	1.0		
E70ACMxx0324xx1xxx	1.0	24	2.0		
E70ACMxx0484xx1xxx	1.0	24	2.0		
E70ACMxx0644xx1xxx	1.2	29	2.0		
E70ACMxx0054xx2xxx	0.8	19	1.0		
E70ACMxx0104xx2xxx	0.8	19	1.0		
E70ACMxx0204xx2xxx	1.0	24	2.0		
E70ACMxx0324xx2xxx	1.4	34	2.0		

$I_{r24}$

Rated current of the device for 24 V supply

$P_{24}$

Rated power of the device for 24 V supply

$I_{max24}$

Maximum device current for the 24 V supply (during start-up of the internal fans, up to 0.5 s)

$C_L$

Charging capacity of the device for 24-V supply



### 4.2.2 Busbar system for the DC bus

The DC busbar system of the i700 device series is dimensioned for 120 A effective current (RMS). It responds to the arising thermal load with a time constant of approximately 5 minutes.

Using an upstream mains choke or mains filter (integrated mains choke) reduces the harmonic content of the mains current and the DC bus current. Hence, the permissible supply power  $P_{DC}$  is increased at 120 A RMS.

Permissible supply power $P_{DC}$ (via the DC busbar system)	Mains voltage	
	400 V	480 V
i700 power supply module <b>with</b> mains choke/filter	≤ 51 kW	≤ 62 kW
i700 power supply module <b>without</b> mains choke/filter	≤ 34 kW	≤ 41 kW

The required supply power  $P_{DC}$  consists of the sum of the power requirement of the single controllers (see also from page 115).

In many cases, the rated power of the controllers  $P_{ar}$  and their power losses  $P_V$  can be added and be compared with the permissible  $P_{DC}$ .

The actual supply power  $P_a$  (mean value via 3 min) can be detected by using familiar travel profiles of the controllers and can be compared with the permissible  $P_{DC}$ .



#### Tip!

The limits of the system only have to be considered in a few applications.

If the compliance cannot be ensure with a simple test, the test can be carried out using the «Drive Solution Designer» PC software.

«DSD» completely maps the required tests for multi-axis systems. This provides for a simple dimensioning of the network. Moreover, an energy-optimised dimensioning of a multi-axis system is possible.

If you do not use «DSD» yet, refer to your Lenze contact.

## 4 Technical data

### Rated data

### Supply modules

#### 4.2.3 Supply modules

##### Basics of the rated data

Mains	Voltage $U_{Lrated}$ [V]	Voltage range $U_{Lrated}$ [V]	Frequency range f [Hz]
3/PE AC	400	320 - 0 % ... 440 + 0 %	45 - 0 % ... 65 + 0 %
3/PE AC	480	432 - 0 % ... 528 + 0 %	45 - 0 % ... 65 + 0 %

Mains	Voltage $U_{DC}$ [V]	Voltage range $U_{DC}$ [V]	Frequency range f [Hz]
2/PE DC	565	455 - 0 % ... 620 + 0 %	-
2/PE DC	675	540 - 0 % ... 746 + 0 %	-

##### Input data

	Voltage [V]	Frequency [Hz]	current [A]		Number of phases
			up to +40 °C <sup>①</sup>	up to +55 °C <sup>①</sup>	
E70ACPSx0304x	400/480	50/60	24.5/24.5	15.3/15.3	3
E70ACPSx0604x	400/480	50/60	49.0/49.0	30.6/30.6	3

<sup>①</sup> Temperature in the control cabinet

## Output data

	Voltage [V]	Frequency [Hz]	Continuous output current [A]		Number of phases	Continuous output power [kW] up to +40 °C <sup>①</sup>	
			up to +40 °C <sup>①</sup>	up to +55 °C <sup>①</sup>		Without Mains choke/filter	With Mains choke/filter
E70ACPSx0304x	565	DC	30.0	18.8	2	10.3	15.4
E70ACPSx0304x	675	DC	30.0	18.8	2	12.3	18.5
E70ACPSx0604x	565	DC	60.0	37.5	2	20.6	30.9
E70ACPSx0604x	675	DC	60.0	37.5	2	24.6	37.0

① Temperature in the control cabinet

Chapter 4.3 contains data for overcurrent operation.

The i700 device series is designed for dynamic applications with several drives (DC-bus operation, (110)).

Usually an acceleration process is followed by a deceleration process, and the motor speeds rarely reach the rated motor speed. Even if a drive is operated at rated power (rated current, rated speed), there are other drives in the network requiring less power.

Therefore, in this case, a power supply module can be dimensioned much smaller than would be required by the total power of the axis controllers.

## Power losses

	Power loss P <sub>V</sub> [W]		
	U <sub>Lr</sub> = 400 V	U <sub>Lr</sub> = 480 V	when controller is inhibited
E70ACPSx0304x	60	60	-
E70ACPSx0304x + EZAELN3025B122	80	80	-
E70ACPSx0604x	110	110	-
E70ACPSx0604x + EZAELN3050B591	160	160	-

**Rated data for internal brake chopper**

To be able to dissipate the excess energy produced during operation in generator mode, the power supply modules are equipped with an internal brake chopper/brake transistor. For this purpose, an external brake resistor corresponding with the technical data from the optional accessories must be connected to X103.

If the DC-bus voltage exceeds 765 V, the brake chopper connects the external brake resistor.

In order to increase the braking power, several power supply modules with a brake chopper and a brake resistor can be used in parallel. Additional information can be obtained from page 121.

Type	R <sub>Bmin</sub> [Ω]	I <sub>BRmax</sub> [A]	P <sub>BRmax</sub> [kW]	I <sub>BRd</sub> [A]	P <sub>Bd</sub> [kW]	t <sub>z</sub> [s]	t <sub>on</sub> [s]	t <sub>fp</sub> [s]
E70ACPSx0304x	18	42.5	32.5	16.7	5.0	97	15	15
E70ACPSx0604x	9	85.0	65.5	33.4	10.1	97	15	15

R <sub>Bmin</sub>	Minimum brake resistance, nominal value ±10 %
I <sub>BRmax</sub>	Peak current
P <sub>BRmax</sub>	Peak braking power
I <sub>BRd</sub>	Continuous current RMS - important for the dimensioning of the cables
P <sub>Bd</sub>	Continuous braking power
t <sub>z</sub>	Cycle time, periodic load change with running time and recovery time
t <sub>on</sub>	Running time
t <sub>z</sub> - t <sub>on</sub>	Recovery time
t <sub>fp</sub>	Maximum running time without initial load and compliance with the recovery time

The trouble-free operation of power supply modules with an external brake resistor is only ensured if an axis module is installed in the immediate vicinity. Preferably by end-to-end mounting and use of the DC busbar system (X101/X102).

## Fuses and cable cross-sections

Operation with external mains choke/mains filter									
Type	Installation according to EN 60204-1 <sup>1)</sup>					Installation according to UL <sup>2)</sup>			FI <sup>3)</sup>
	①	②	L1, L2, L3 - Laying system			①	③	L1, L2, L3	
	[A]	[A]	B2 [mm <sup>2</sup> ]	C [mm <sup>2</sup> ]	F [mm <sup>2</sup> ]	[A]	[A]	[AWG]	
E70ACPSxQ304x	C40	40	10	6	-	40	40	8	≥ 300
E70ACPSxQ604x	C63	63	16	10	-	-	60	6	≥ 300

<sup>1)</sup> The data are recommendations. Other designs/laying systems are possible (e.g. in accordance with VDE 0298-4). The cable cross-sections apply under the following conditions: use of PVC-insulated copper cables, conductor temperature < 70 °C, ambient temperature < 45 °C, no cable or core bundling, three loaded cores.

<sup>2)</sup> Only use UL-approved cables, fuses, and fuse holders.

UL fuse: voltage ≥ 500 V, tripping characteristic "J", "T", or "G". The cable cross-sections apply under the following conditions: conductor temperature < 75 °C, ambient temperature < 45 °C.

<sup>3)</sup> Universal-current sensitive earth-leakage circuit breaker, short-time delayed, type B

In the case of cable lengths > 50m, depending on the cable type and the switching frequency, the circuit-breaker may respond.

① Circuit breaker

② Fuse of gG/gL utilisation category or semiconductor fuses of gRL utilisation category

③ Fuse

Observe national and regional regulations

## 4 Technical data

Rated data  
Axis modules

### 4.2.4 Axis modules

#### Basics of the rated data

Mains	Voltage $U_{DC}$ [V]	Voltage range $U_{DC}$ [V]	Frequency range $f$ [Hz]
2/PE DC	565	455 - 0 % ... 620 + 0 %	-
2/PE DC	675	540 - 0 % ... 746 + 0 %	-

#### Input data

	Voltage [V]	Frequency [Hz]	current [A]		Number of phases
			up to +40 °C <sup>①</sup>	up to +55 °C <sup>①</sup>	
E70ACMxx0054xx1xxx	565/675	DC	5.0/4.9	3.1/3.1	2
E70ACMxx0104xx1xxx	565/675	DC	9.3/9.2	5.8/5.8	2
E70ACMxx0204xx1xxx	565/675	DC	18.7/18.5	11.7/11.6	2
E70ACMxx0324xx1xxx	565/675	DC	29.8/29.7	18.6/18.6	2
E70ACMxx0484xx1xxx	565/675	DC	44.6/44.5	27.9/27.9	2
E70ACMxx0644xx1xxx	565/675	DC	59.2/59.1	37.0/37.0	2
E70ACMxx0054xx2xxx	565/675	DC	9.3/9.2	5.8/5.8	2
E70ACMxx0104xx2xxx	565/675	DC	18.7/18.5	11.7/11.6	2
E70ACMxx0204xx2xxx	565/675	DC	37.0/36.9	23.1/23.0	2
E70ACMxx0324xx2xxx	565/675	DC	59.2/59.1	37.0/37.0	2

<sup>①</sup> Temperature in the control cabinet

## Output data

The axis modules E70ACM... generate the output power at switching frequencies of 4, 8 and 16 kHz. The switching frequency of 2 kHz used of controllers of other device series is not used.

The rated switching frequency is preset with 4 kHz. In general, the rated current ( $I_{aM4}$ ) and the maximum current ( $I_{aM4}$ ) refer to the rated switching frequency.

8 and 16 kHz are parameterised as standard switching frequency. These are variable switching frequencies. If the permissible continuous current for these switching frequencies is exceeded, it is automatically switched back to the next lower switching frequency.

When the axis modules E70ACM... are used, the maximum output current (overload current) is only possible at a rated switching frequency of 4 kHz.

Dynamic load change cycles with recovery times are defined for the maximum output current. In the recovery time, the current has to be limited to 75 % of the rated current at 4 kHz. For certain axis modules, the use of load change cycles at output frequencies 0 ... 5 Hz is restricted.

Data for operation at a switching frequency of 4 kHz.

	Spannung [V]	Frequenz <sup>1)</sup> [Hz]	Dauerausgangsstrom [A]		Phasenzahl
			bis +40 °C <sup>①</sup>	bis +55 °C <sup>①</sup>	
E70ACMxx0054xx1xxx	0 ... 400/480	0 ... 500	2.5/2.5	1.6/1.6	3
E70ACMxx0104xx1xxx	0 ... 400/480	0 ... 500	5.0/5.0	3.1/3.1	3
E70ACMxx0204xx1xxx	0 ... 400/480	0 ... 500	10.0/10.0	6.3/6.3	3
E70ACMxx0324xx1xxx	0 ... 400/480	0 ... 500	16.0/16.0	10.0/10.0	3
E70ACMxx0484xx1xxx	0 ... 400/480	0 ... 500	24.0/24.0	15.0/15.0	3
E70ACMxx0644xx1xxx	0 ... 400/480	0 ... 500	32.0/32.0	20.0/20.0	3
E70ACMxx0054xx2xxx	0 ... 400/480	0 ... 500	2 * 2.5/2.5	2 * 1.6/1.6	3
E70ACMxx0104xx2xxx	0 ... 400/480	0 ... 500	2 * 5.0/5.0	2 * 3.1/3.1	3
E70ACMxx0204xx2xxx	0 ... 400/480	0 ... 500	2 * 10.0/10.0	2 * 6.3/6.3	3
E70ACMxx0324xx2xxx	0 ... 400/480	0 ... 500	2 * 16.0/16.0	2 * 10.0/10.0	3

① Temperature in the control cabinet

<sup>1)</sup> Table value valid at switching frequency = 4 kHz

E70ACMSxxxx4xxxxx:

At switching frequency = 8 kHz, the max. output frequency is 1000 Hz.

At switching frequency = 16 kHz, the max. output frequency is 2000 Hz.

E70ACMDxxxx4xxxxx:

The max. output frequency is limited to 599 Hz.

Testing of the axis modules via +UG, -UG is possible if  $U_{DC} \geq 30$  V.

Provision of the 24-V supply at X21 (power supply module) / X3 (axis module) is required.

## Switching frequency-dependent output currents

## 400 V

	Output currents [A] at switching frequency						
	2 kHz		4 kHz		8 kHz		16 kHz
	$I_{aN2}$	$I_{aM2}$	$I_{aN4}$	$I_{aM4}$	$I_{aN8}$	$I_{aM8}$	$I_{aN16}$
E70ACMxx0054xx1xxx	-	-	<b>2.5</b>	5.0	2.5	-	1.5
E70ACMxx0104xx1xxx	-	-	<b>5.0</b>	10.0	5.0	-	3.0
E70ACMxx0204xx1xxx	-	-	<b>10.0</b>	20.0	10.0	-	6.0
E70ACMxx0324xx1xxx <sup>1)</sup>	-	-	<b>16.0</b>	32.0	12.8	-	9.6
E70ACMxx0484xx1xxx <sup>1)</sup>	-	-	<b>24.0</b>	48.0	19.2	-	14.4
E70ACMxx0644xx1xxx <sup>1)</sup>	-	-	<b>32.0</b>	64.0	25.6	-	19.2
E70ACMxx0054xx2xxx	-	-	<b>2 * 2.5</b>	2 * 5.0	2 * 2.5	-	2 * 1.5
E70ACMxx0104xx2xxx	-	-	<b>2 * 5.0</b>	2 * 10.0	2 * 5.0	-	2 * 3.0
E70ACMxx0204xx2xxx	-	-	<b>2 * 10.0</b>	2 * 20.0	2 * 10.0	-	2 * 6.0
E70ACMxx0324xx2xxx <sup>1)</sup>	-	-	<b>2 * 16.0</b>	2 * 32.0	2 * 12.8	-	2 * 9.6

## 480 V

	Output currents [A] at switching frequency						
	2 kHz		4 kHz		8 kHz		16 kHz
	$I_{aN2}$	$I_{aM2}$	$I_{aN4}$	$I_{aM4}$	$I_{aN8}$	$I_{aM8}$	$I_{aN16}$
E70ACMxx0054xx1xxx	-	-	<b>2.5</b>	5.0	2.5	-	1.5
E70ACMxx0104xx1xxx	-	-	<b>5.0</b>	10.0	5.0	-	2.4
E70ACMxx0204xx1xxx	-	-	<b>10.0</b>	20.0	10	-	4.8
E70ACMxx0324xx1xxx <sup>1)</sup>	-	-	<b>16.0</b>	32.0	12.8	-	7.7
E70ACMxx0484xx1xxx <sup>1)</sup>	-	-	<b>24.0</b>	48.0	19.2	-	11.5
E70ACMxx0644xx1xxx <sup>1)</sup>	-	-	<b>32.0</b>	64.0	25.6	-	15.4
E70ACMxx0054xx2xxx	-	-	<b>2 * 2.5</b>	2 * 5.0	2 * 2.5	-	2 * 1.5
E70ACMxx0104xx2xxx	-	-	<b>2 * 5.0</b>	2 * 10.0	2 * 5.0	-	2 * 2.4
E70ACMxx0204xx2xxx	-	-	<b>2 * 10.0</b>	2 * 20.0	2 * 10.0	-	2 * 4.8
E70ACMxx0324xx2xxx <sup>1)</sup>	-	-	<b>2 * 16.0</b>	2 * 32.0	2 * 12.8	-	2 * 7.7

$I_{aNx}$  Rated value of continuous output current

**$I_{aNx}$**  Nominal value  $I_{aN}$

$I_{aMx}$  Maximum output current (overload current, 42)

- dynamic load change cycle of 3 s with  $I_{aM4}$  and recovery time of 12 s with 75 %  $I_{aN4}$

<sup>1)</sup> Restriction for output frequencies 0 ... 5 Hz

- dynamic load change cycle of 0.5 s with  $I_{aM4}$  and recovery time of 2 s with 75 %  $I_{aN4}$

If the output currents specified for a switching frequency of 16 kHz and 8 kHz are exceeded, the switching frequency is automatically reduced to the next lower switching frequency.



**Power losses**

	Power loss $P_V$ [W]		
	$U_{Lr} = 400\text{ V}$	$U_{Lr} = 480\text{ V}$	when controller is inhibited
E70ACMxx0054xx1xxx	50	50	20
E70ACMxx0104xx1xxx	80	80	20
E70ACMxx0204xx1xxx	130	130	20
E70ACMxx0324xx1xxx	210	210	35
E70ACMxx0484xx1xxx	290	300	35
E70ACMxx0644xx1xxx	390	390	45
E70ACMxx0054xx2xxx	90	90	30
E70ACMxx0104xx2xxx	140	150	30
E70ACMxx0204xx2xxx	260	260	45
E70ACMxx0324xx2xxx	370	380	45

**4.3 Overcurrent operation**

Power supply modules and axis modules can be operated with currents exceeding the rated current if the time interval of this overcurrent operation is limited. Within the utilisation cycles, an overcurrent is possible for a certain time if afterwards an accordingly long recovery phase takes place. Two utilisation cycles with a duration of 15 s and 180 s are defined.

- ▶ 15-s cycle ①
  - 3 s load period with peak current  $I_A$  (200 %)
  - 12 s recovery time with limited current  $I_B$  (75 %)
- ▶ 180-s cycle ②
  - 60 s load period with peak current  $I_C$  (150 %)
  - 120 s recovery time with limited current  $I_D$  (75 %)

A load period must be followed by a recovery time. During the recovery time the current must not exceed the value given.

The values given refer to the rated output current.

- ▶  $I_{rdc}$  for power supply modules
- ▶  $I_{ar4}$  for axis modules

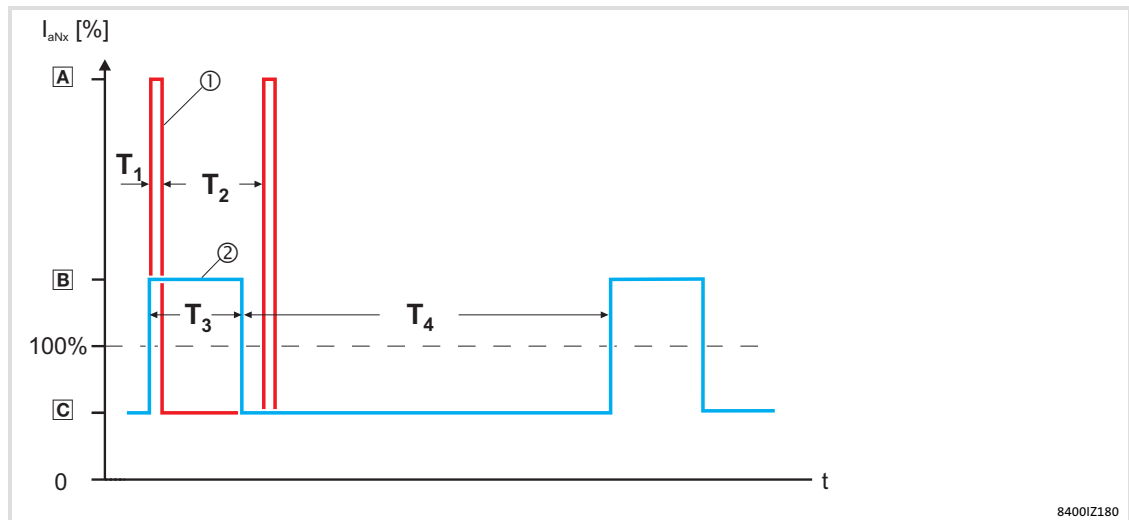

Fig. 4-1 Overcurrent capacity at 40° C

- ① Pulse utilisation (15 s cycle)
- Ⓐ Peak current
- Ⓒ Unloading current
- $T_1$  Peak current period
- $T_2$  Unloading current period
  
- ② Permanent load (180 s cycle)
- Ⓑ Peak current
- Ⓒ Unloading current
- $T_3$  Peak current period
- $T_4$  Unloading current period
- $I_{aNx}$  Rated value of continuous output current



**Tip!**

For calculations of application-specific cycles please contact your Lenze contact person.

## 4.3.1 Supply modules

Power supply modules	Short-time currents [A] acc. to cycle times				
	$I_{rdc}$	3 / 12 s		60 / 120 s	
		200% $I_{max\_3}$	75% $I_{red\_12}$	150% $I_{max\_60}$	75% $I_{red\_120}$
E70ACPSx0304x	30.0	60.0	19.8	45.0	22.5
E70ACPSx0604x	60.0	120	39.6	90.0	45.0

## 4.3.2 Axis modules

Axis modules	Short-time currents [A] at switching frequency of 4 kHz acc. to cycle times				
	$I_{r4}$	3 / 12 s		60 / 120 s	
		200% $I_{max4\_3}$	75% $I_{red4\_12}$	150% $I_{max4\_60}$	75% $I_{red4\_120}$
E70ACMxx0054xx1xxx	2.5	5.0	1.9	3.8	1.9
E70ACMxx0104xx1xxx	5.0	10.0	3.8	7.5	3.8
E70ACMxx0204xx1xxx	10.0	20.0	7.5	15.0	7.5
E70ACMxx0324xx1xxx	16.0	32.0	12.0	24.0	12.0
E70ACMxx0484xx1xxx	24.0	48.0	18.0	36.0	18.0
E70ACMxx0644xx1xxx	32.0	64.0	24.0	48.0	24.0
E70ACMxx0054xx2xxx	2 * 2.5	2 * 5.0	2 * 1.9	2 * 3.8	2 * 1.9
E70ACMxx0104xx2xxx	2 * 5.0	2 * 10.0	2 * 3.8	2 * 7.5	2 * 3.8
E70ACMxx0204xx2xxx	2 * 10.0	2 * 20.0	2 * 7.5	2 * 15.0	2 * 7.5
E70ACMxx0324xx2xxx	2 * 16.0	2 * 32.0	2 * 12.0	2 * 24.0	2 * 12.0

## 4.4 Terminal description

### 4.4.1 Supply modules

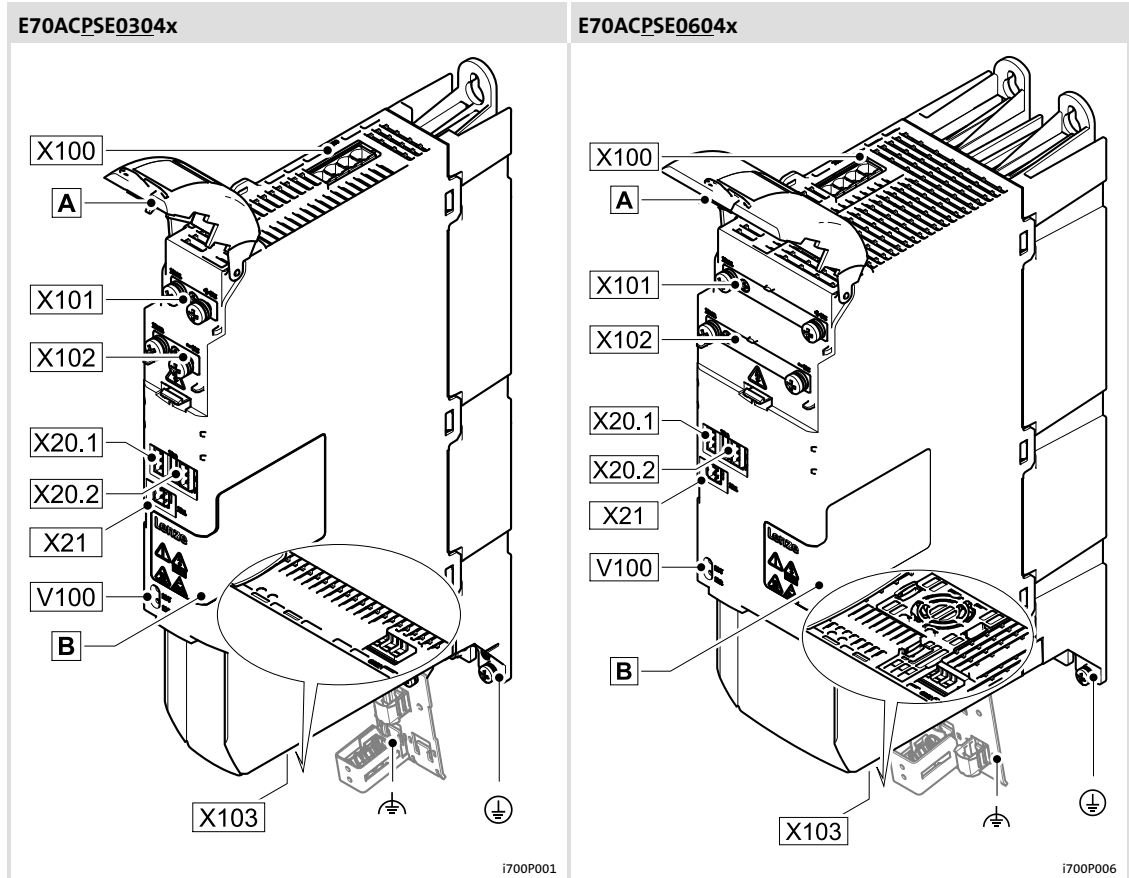

Connections and elements		Info
A	Hinged cover of DC-bus connections	49
B	Nameplate and warning symbols	24
X20.1	Digital inputs, digital outputs	47
X20.2	Digital inputs, digital outputs	47
X21	External 24-V supply	46
X100	Mains connection	48
X101	DC-bus UG+	49
X102	DC-bus UG-	49
X103	Connection of brake resistor	50
V100	LED status display	127
⊕	PE conductor	103
⊕	Shield connection (functional earth)	103

### External voltage supply

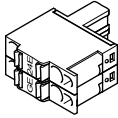
X21	Labelling	Description
 i700PX021	24E	24-V supply voltage of control electronics from a safely separated power supply unit (SELV/PELV)
	GE	Reference potential (GND)

Terminal data					
	Conductor cross-section		Tightening torque		
	[mm <sup>2</sup> ]	[AWG]	[Nm]	[lb-in]	
flexible	0.2 ... 2.5	24 ... 12	-	-	3.5 x 0.6

X21 Electrical data			
24E	Rated voltage	24 V	in accordance with IEC 61131-2
GE	Voltage range	19.2 ... 28.8 V	
	Residual ripple	Max. ± 5 %	
	Current consumption	See technical data,  4.2.1	
	Polarity reversal protection	When polarity is reversed: no function and no destruction.	
	Cable protection	Circuit breaker with tripping characteristic B or C Standard blade-type fuses	

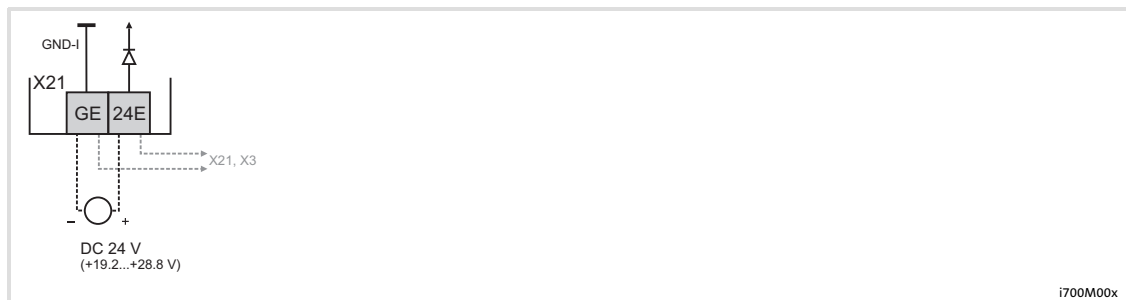
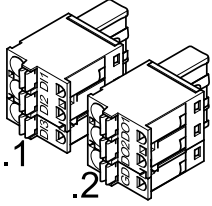



Fig. 1 Wiring of X21

X21	Connection of the control electronics supply voltage at the power supply module, can be looped through to other power supply or axis modules
24E	DC 24 V, acc. to IEC IEC 61131-2, SELV/PELV
GE	Reference potential GND

### Digital inputs, digital outputs

X20	Labelling	Description	
 i700PX020	DI1	External brake chopper control	X20.1: digital inputs
	DI2	TRIP reset	
	DI3	SLAVE activation	
	DO1	Brake chopper status output	X20.2: digital outputs Diagnostic information:  126
	DO2	Error message	
	GD	Reference potential GND	For DI1, DI2, DI3, DO1, DO2

Terminal data					
	Conductor cross-section		Tightening torque		
	[mm <sup>2</sup> ]	[AWG]	[Nm]	[lb-in]	
flexible	0.2 ... 2.5	24 ... 12	-	-	3.5 x 0.6

X20	Electrical data		
	Rated voltage	24 V	in accordance with IEC 61131-2
	Voltage range	19.2 ... 28.8 V	
	Residual ripple	Max. ± 5 %	
DI1 DI2 DI3	Current consumption	Max. 8 mA	
	Polarity reversal protection	When polarity is reversed: no function and no destruction.	
DO1 DO2	Current	Max. 50 mA	
GD	Reference potential	0 V	

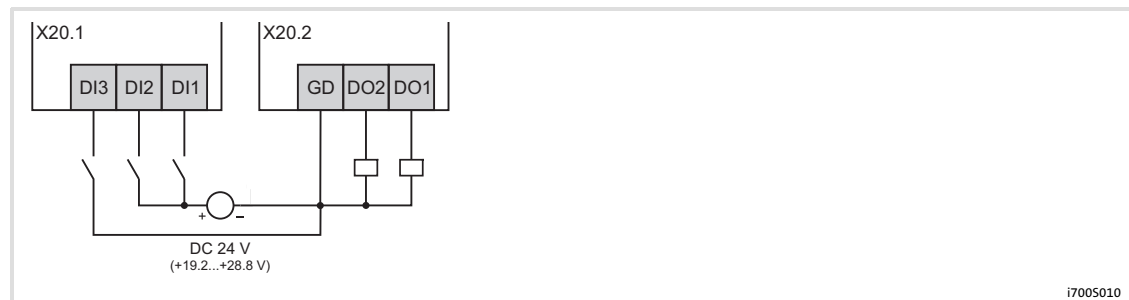
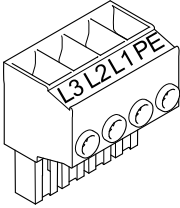



Fig. 2 Wiring of X20

- |     |   |
|-----|---|
| X20 | Connection of digital inputs and outputs at the power supply module |
| .1  | Connector on the left-hand side                                     |
| .2  | Connector on the right-hand side                                    |
| DIx | Digital input   |
| DOx | Digital output (e.g. for controlling relays)                        |
| GD  | Reference potential GND   |

### Mains connection

X100	Labelling	Description
 i700P003	PE	Protective earth ⊕
	L1	Mains phases 3 PE / AC 400/480 V
	L2	
	L3	

Terminal data					
	Conductor cross-section		Tightening torque		
	[mm <sup>2</sup> ]	[AWG]	[Nm]	[lb-in]	
flexible	0.5 ... 16	22 ... 6	1.2 ... 1.5	10.6 ... 13.3	5.5 x 1

X100	Electrical data	
L1	Rated voltage	400/480 V
L2		
L3	Voltage range	320 ... 528 V
PE		

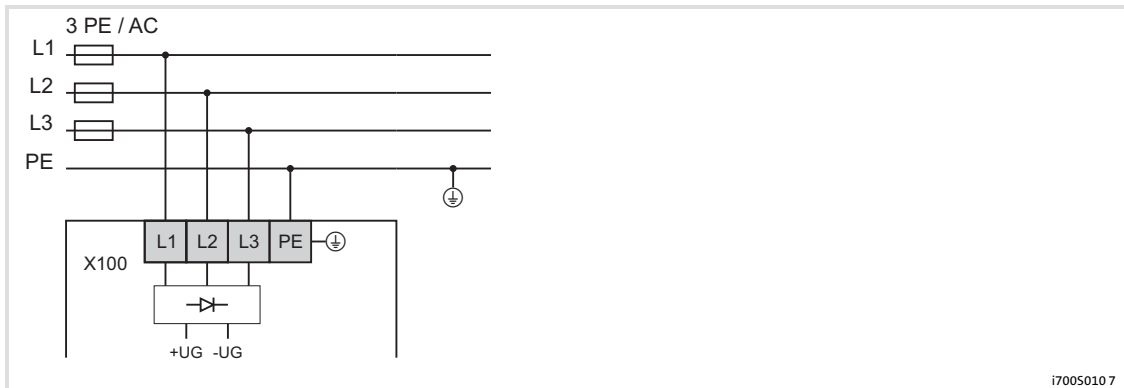
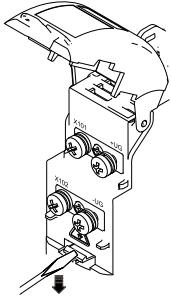

Fig. 3 Wiring of X100

X100	Mains voltage connection of power supply module
L1, L2, L3	Mains phases 3 / AC
PE	PE conductor, ⊕
UG (+, -)	DC bus



### Connection to the DC bus (+U<sub>G</sub>, -U<sub>G</sub>)

X101/X102	Labelling	Description
 <p>i700PX1012</p>	UG+	DC-bus voltage UG+
	UG-	DC-bus voltage UG-
		<p><b>Open the protection cover only if the device is deenergised!</b> To open the protection cover, press the lock between the clips of the cover down using a screwdriver and swivel the protection cover away from the device at the same time.</p>

#### Terminal data

	Conductor cross-section		Tightening torque		 PH 3
	[mm <sup>2</sup> ]	[AWG]	[Nm]	[lb-in]	
Swivel hook	-	-	5.0	44.3	PH 3

X101 X102	Electrical data	
UG+	Rated voltage	565/675 V
UG-	Current	Up to 40 °C: 120 A 40 ... 55 °C: -2.5 %/K
	Polarity reversal protection	For internal connection: not relevant

### Connection of external brake resistor

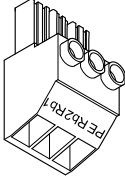
X103	Labelling	Description
 i700PX103	Rb1	Connection of brake resistor
	Rb2	
	PE	Protective earth ⊕

Terminal data					
	Conductor cross-section		Tightening torque		
	[mm <sup>2</sup> ]	[AWG]	[Nm]	[lb-in]	
flexible	0.5 ... 6	22 ... 10	0.5 ... 0.6	4.4 ... 5.3	4.5 x 0.8

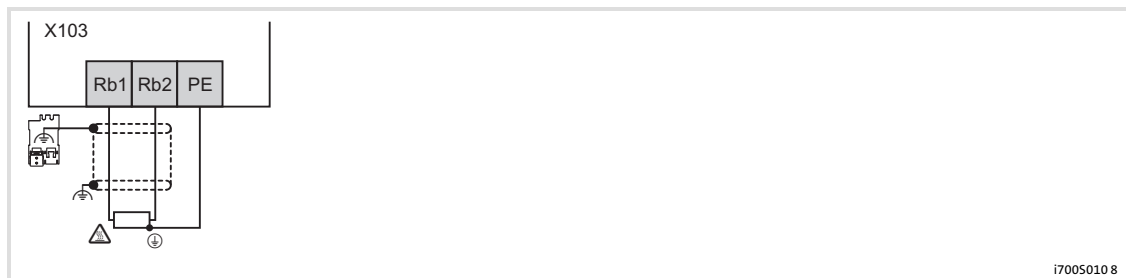

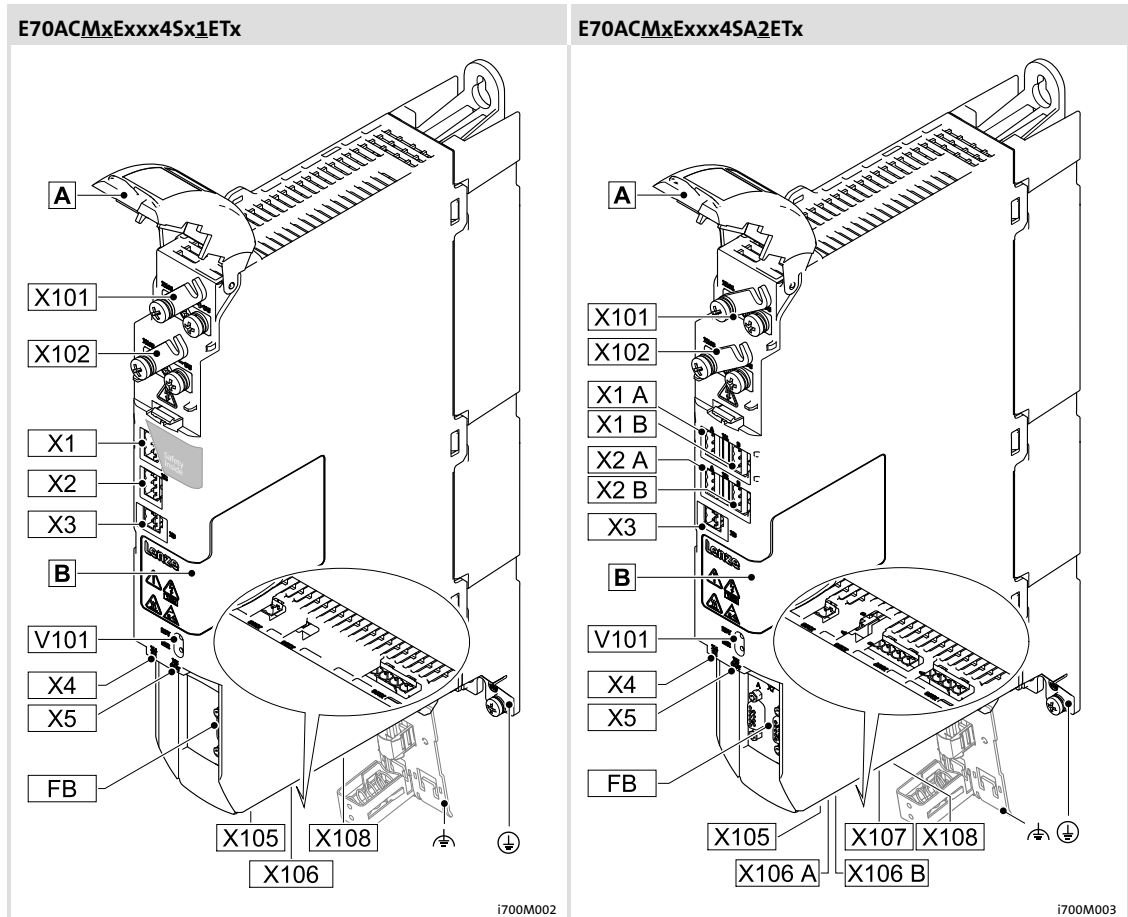

Fig. 4 Wiring of X103

X103	Connection of brake resistor
Rb1, Rb2	Brake resistor corresponding with rated data
	Functional earth  , shield connection

The shielded cable for connection of a brake resistor is prepared in the same way as a motor cable (64). The free length of the cores for Rb1/Rb2 is to be 160 mm (PE: + 10 mm).

4.4.2 Axis modules



Connections and elements		Info
▣	Hinged cover of DC-bus connections	49
▣	Nameplate and warning symbols	24
V101	LED status display	127
X1 A/B	Integrated safety system	128
X2 A/B	Touch probe	53
X3	External 24-V supply	54
X4	EtherCAT IN	55
X5	EtherCAT OUT	
FB	Servo control feedback system (alternative)	
	X7 A/B - Resolver (E70ACM...R)	57
	X8 A/B - Encoder (E70ACM...E)	59
X101	DC-bus UG+	61
X102	DC-bus UG-	
X105	24-V supply of motor holding brake	62
X106 A/B	Motor holding brake	63
X107	Motor - axis B	64
X108	Motor - axis A	
⊕	PE conductor	103
⊕	Shield connection (functional earth)	103

**Integrated safety engineering**



Further information on the use of this connection can be found ...

- ▶ in the chapter "Safety engineering" if the "STO" safety function is to be used (128).
- ▶ in the chapter "Electrical installation" if safety functions will not be used (107).

**E70ACMxxxxx4xAxETx - Basic Safety - STO**

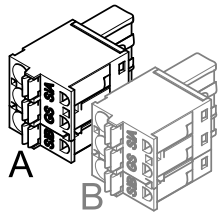
X1	Labelling	Description	
 <p style="text-align: center; font-size: small;">i700P00x</p>	SIA	Safe input, channel A	On double axis devices, there are two of these connections. For the assignment to the axes, the designations "A" / "B" are used. Independently of this, the two-channel safe input is always provided with the channels A and B.
	GS	Reference potential GND	
	SIB	Safe input, channel B	

### Digital inputs

X2	Labelling	Description	
<p>i700P00x</p>	DI1	Touch probe inputs	On double axis devices, there are two of these connections. For the assignment to the axes, the designations "A" / "B" are used.
	DI2		
	GD	Reference potential GND	

Terminal data					
	Conductor cross-section		Tightening torque		
	[mm <sup>2</sup> ]	[AWG]	[Nm]	[lb-in]	
flexible	0.2 ... 2.5	24 ... 12	-	-	3.5 x 0.6

X2	Electrical data		
DI1	Rated voltage	24 V	in accordance with IEC 61131-2
DI2	Voltage range	19.2 ... 28.8 V	
	Residual ripple	Max. ± 5 %	
	Current consumption	Max. 8 mA	
	Polarity reversal protection	When polarity is reversed: no function and no destruction.	
GD	Reference potential	0 V	





Fig. 5 Wiring of X2

- X2 Connection of digital inputs of axis module
- A 1-axis module
- B Additionally for 2-axis module
- DIx Digital input
- GD Reference potential GND

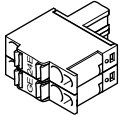
## External voltage supply

X3	Labelling	Description
 i700P00x	24E	24-V supply voltage of control electronics from a safely separated power supply unit (SELV/PELV)
	GE	Reference potential (GND)

Terminal data					
	Conductor cross-section		Tightening torque		
	[mm <sup>2</sup> ]	[AWG]	[Nm]	[lb-in]	
flexible	0.2 ... 2.5	24 ... 12	-	-	3.5 x 0.6

X3	Electrical data		
24E	Rated voltage	24 V	in accordance with IEC 61131-2
GE	Voltage range	19.2 ... 28.8 V	
	Residual ripple	Max. $\pm 5\%$	
	Current consumption	See technical data,  4.2.1	
	Polarity reversal protection	When polarity is reversed: no function and no destruction.	
	Cable protection	Circuit breaker with tripping characteristic B or C Standard blade-type fuses	

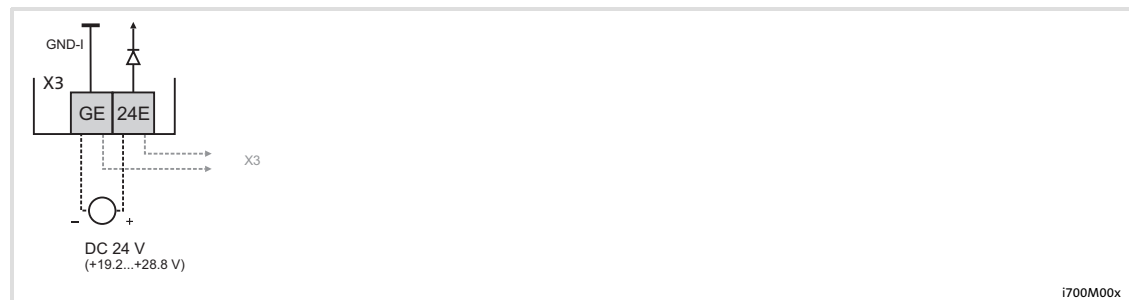
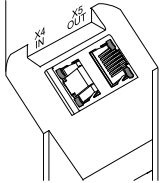

Fig. 6 Wiring of X3

X3	Supply voltage connection of axis module control electronics, can be looped through
24E	DC 24 V, acc. to IEC 61131-2, SELV/PELV
GE	Reference potential GND

**EtherCAT®**

X4/X5	Labelling	Description	
 <p data-bbox="496 577 584 602">i700AX045 a</p>	IN	EtherCAT input	RJ45 socket with one LED status display for diagnostics
	OUT	EtherCAT output	RJ45 socket with two LED status displays for diagnostics

X4 X5	Electrical data		
	Acc. to EtherCAT Technology Group (ETG)		

**Connection of feedback system**

Over two hardware variants, the axis modules support the following feedback systems (motor encoders) for servo control:

- ▶ The E70ACM...R types support resolvers.
  - On the X7 connection (A/B), 9-pole Sub-D socket
- ▶ The E70ACM...E types support SinCos encoders
  - On the X8 connection (A/B), 15-pole Sub-D socket

In the case of double axis modules, the hardware variant is designed in the same way for both axes. Operation with different encoder types on one double axis module is not possible.

At the motor encoder terminal (X7/X8), a PTC sensor can also be connected and evaluated instead of a KTY sensor. A correct setting of the sensor type for motor temperature monitoring is required (see reference manual).

Ensure an electrically protective separation of the KTY or PTC sensors from the motor voltage potential:

**Danger!****Hazardous electrical voltage**

In the event of an error, control terminals can carry a hazardous electrical voltage due to unsuitable KTY or PTC sensors.

**Possible consequences:**



- ▶ Contact may result in fatal injuries.

**Protective measures:**

- ▶ Only connect motors with safely separated KTY or PTC sensors.

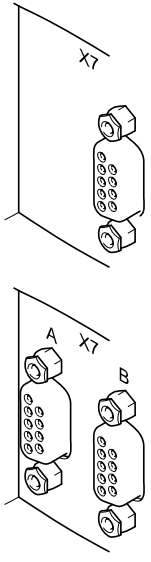

Resolver

X7	Pin	Description	
 <p>i700AX007 a b</p>	E70ACM...R		
	1	+REF	On single axis devices, this connection is located on the right-hand side below the labelling "X7".
	2	-REF	
	3	n. c.	
	4	+COS	
	5	-COS	
	6	+SIN	On double axis devices, there are two of these connections. For the assignment to the axes, the designations "A" / "B" are used.
	7	-SIN	
	8	+KTY	
	9	-KTY	
		Shield connection at Sub-D housing	

X7	Electrical data		
	General	Cable length (system cable is recommended)	Max. 50 m
3	n. c.		
1, 2	+REF, -REF	Input frequency	max. 250 kHz
4, 5	+COS, -COS	Excitation voltage	10 V <sub>SS</sub>
6, 7	+SIN, -SIN	Carrier frequency	4 kHz, constant value
8, 9	+KTY, -KTY	Type	KTY 83-110

Resolvers are connected to X7 (9-pole Sub-D socket).

The use of third-party resolvers is permissible. For this purpose, the number of pole pairs of the resolver saved in parameter 0x2C43 (0x3443) must be adapted to the used resolver. If the stator coils are excited with 4 kHz, the apparent impedance of the connected resolver must not fall below a value of 65 ohms. If smaller impedances are connected, the overload protection integrated in the resolver output limits the output current and can falsify the resolver evaluation.

Resolvers are operated in reverse mode:

- ▶ Supply to the sine and cosine track,
- ▶ Both signals are controlled in a way that the current flow on the reference track is reduced to zero.

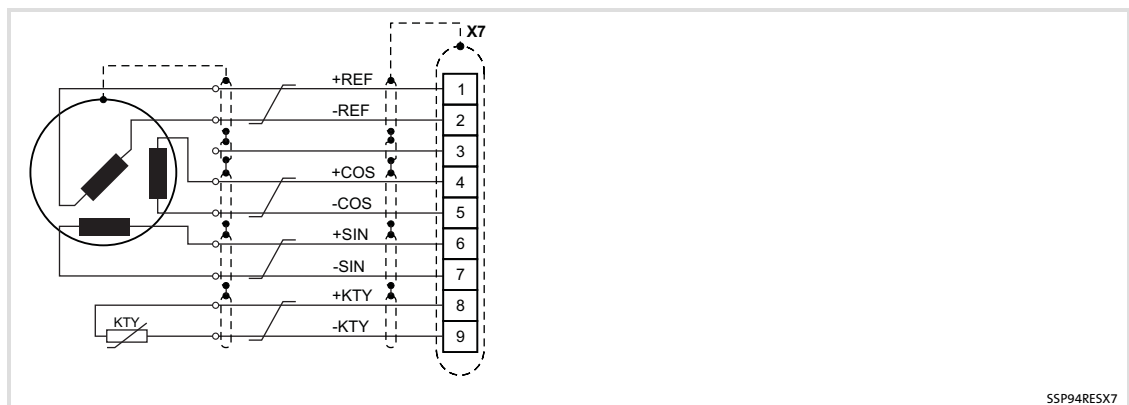
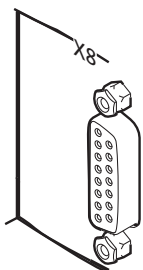
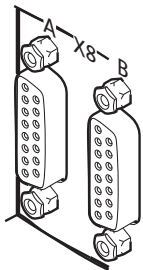

Fig. 4-2 Wiring principle

Encoder

X8	Pin	Description		
		EYF001... cable 1 V <sub>SS</sub>	1 V <sub>SS</sub> Hiperface	
 	E70ACM...E			
	1	A	COS	On single axis devices, this connection is located on the right-hand side below the labelling "X8".
	2	GND	GND	
	3	B	Sin	
	4	V <sub>CC</sub>	V <sub>CC</sub>	
	5	Z	+RS485	
	6	n. c.	n. c.	
	7	-KTY	-KTY	
	8	n. c.	n. c.	
	9	/A	Ref COS	On double axis devices, there are two of these connections. For the assignment to the axes, the designations "A" / "B" are used.
	10	n. c.	n. c.	
	11	/B	Ref SIN	
	12	n. c.	n. c.	
	13	/Z	-RS485	
	14	+KTY	+KTY	
15	n. c.	n. c.		
				Shield connection at Sub-D housing

i700AX007 a b

Electrical data		
General	Cable length (system cable is recommended)	Max. 50 m
	Encoder types	Sin/cos encoder, 1V <sub>SS</sub>
	Protocols	Hiperface®
	Number of increments	1 ... 16383
	Input frequency	max. 250 kHz
	VCC (GND)	Supply voltage
Current, max.		9 V
		12 V
+KTY, -KTY	Type	KTY 83-110

Encoders are connected to X8 (15-pole Sub-D socket).

To avoid interference injection, only use shielded motor and encoder cables if an encoder is used.

- ▶ Absolute and incremental encoders are supported:
  - Sin/cos encoders 1 V<sub>SS</sub> (incremental)
  - SinCos absolute value encoder 1 V<sub>SS</sub> with Hiperface® protocol
- ▶ Sin/cos absolute value encoders are read out by default during initialisation (switch-on of the supply voltage). Then, the sin/cos signals are evaluated.
- ▶ Open-circuit monitoring:
  - Sin/cos encoders: Comparison of the sin/cos signals and the sine-wave form (radius monitoring)

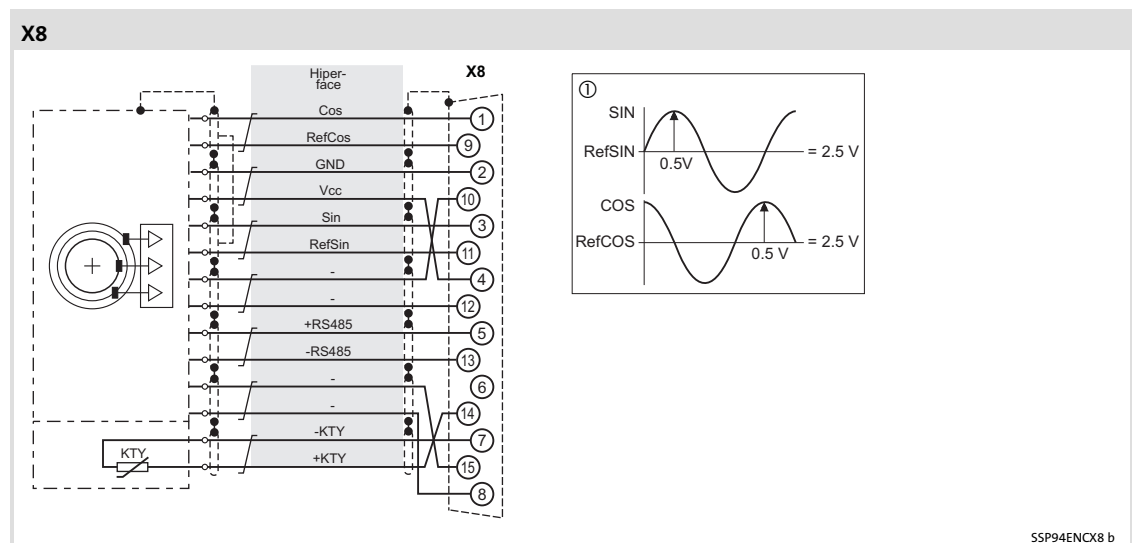
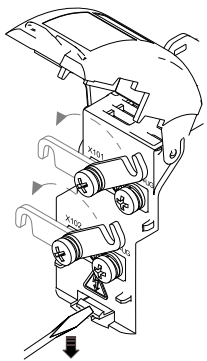



Fig. 4-3 Wiring principle

### Connection to the DC bus (+U<sub>G</sub>, -U<sub>G</sub>)

X101/X102	Labelling	Description
 <p>i7005X1012</p>	UG+	DC-bus voltage UG+
	UG-	DC-bus voltage UG-
	<p><b>Open the protection cover only if the device is deenergised!</b> To open the protection cover, press the lock between the clips of the cover down using a screwdriver and swivel the protection cover upwards.</p>	

Terminal data					
	Conductor cross-section		Tightening torque		 PH 3
	[mm <sup>2</sup> ]	[AWG]	[Nm]	[lb-in]	
Swivel hook	-	-	5.0	44.3	PH 3

X101 X102	Electrical data	
UG+	Rated voltage	565/675 V
UG-	Current	Up to 40 °C: 120 A 40 ... 55 °C: -2.5 %/K
	Polarity reversal protection	For internal connection: not relevant

## Brake connection

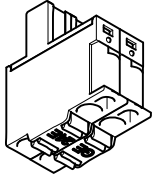
X105	Labelling	Description
 i700P00x	24E	24 V supply voltage for motor holding brakes
	GE	Reference potential GND

On double axis devices, there is one of these connections. The motor holding brakes of axis A and B are supplied.

Terminal data					
	Conductor cross-section		Tightening torque		
	[mm <sup>2</sup> ]	[AWG]	[Nm]	[lb-in]	
flexible	0.2 ... 2.5	24 ... 12	-	-	3.5 x 0.6

X105	Electrical data		
24E	Rated voltage	24 V	The supply voltage of the motor holding brake must be independent. A safely separated supply is not required.  87
GE	Voltage range	18 ... 30 V	
	Current consumption	Corresponding to the connected brake	
	Terminal current when looped through	With 1.5 mm <sup>2</sup> : max. 10 A With 2.5 mm <sup>2</sup> : max. 16 A	
	Polarity reversal protection	When the polarity is reversed: no function and no destruction.	
	Cable protection	Circuit breaker with tripping characteristic B or C Standard blade-type fuses	
			≤ 20 A, ≥ 30 V

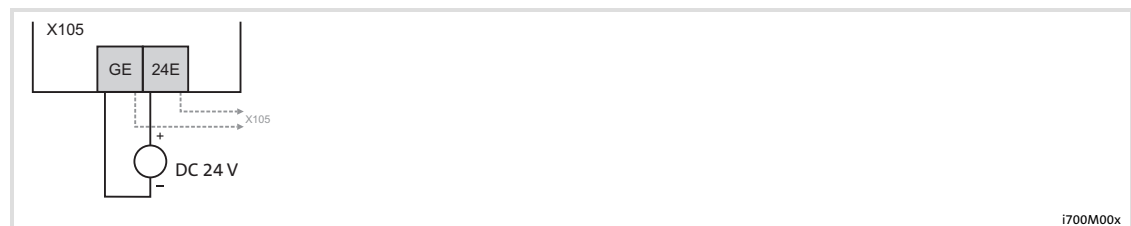
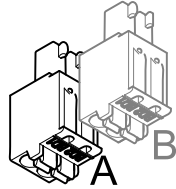



Fig. 7 Wiring of X105

X105	Supply voltage connection of motor holding brake, can be looped through
24E	24-V supply voltage for motor holding brakes
GE	Reference potential

X106	Labelling	Description	
 i700P00x	BD1	Motor holding brake (+)	On double axis devices, there are two of these connections. For the assignment to the axes, the designations "A" / "B" are used.
	BD2	(-)	

Terminal data					
	Conductor cross-section		Tightening torque		
	[mm <sup>2</sup> ]	[AWG]	[Nm]	[lb-in]	
flexible	0.2 ... 1.5	24 ... 16	-	-	3.5 x 0.6

X106	Electrical data	
BD1	Voltage	24 V
BD2	Voltage range	Depending on the external voltage source for controlling the brake(s)
	Current consumption	Corresponding to the connected brake
	Polarity reversal protection	Not relevant

X106	Maximum switchable current for connected brakes
	[A]
E70ACMxx0054xx1xxx E70ACMxx0104xx1xxx E70ACMxx0204xx1xxx	1.5
E70ACMxx0054xx2xxx E70ACMxx0104xx2xxx E70ACMxx0204xx2xxx	2 x 1.5
E70ACMxx0324xx1xxx E70ACMxx0484xx1xxx E70ACMxx0644xx1xxx	2.5
E70ACMxx0324xx2xxx	2 x 2.5

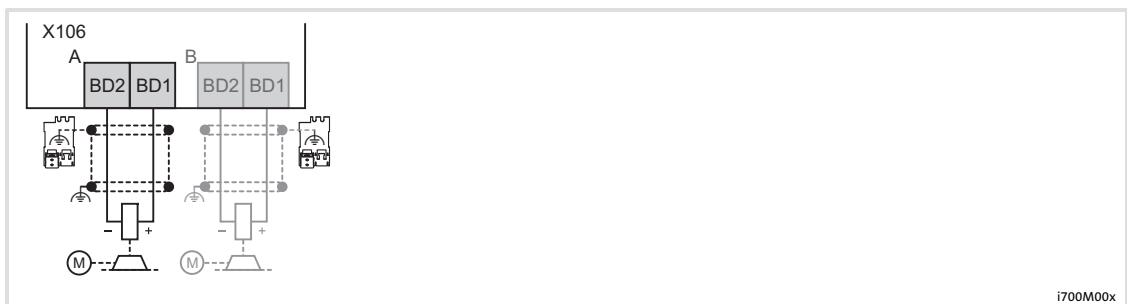



Fig. 8 Wiring of X106

X106  
A, B  
BD1, BD2

Connection of a motor holding brake  
A: 1-axis module, B: additionally for 2-axis module  
Coil voltage 24 V DC  
(observe correct polarity for permanent magnet brakes)  
Functional earth , shield connection 

**Motor connection**

X107/108	Labelling	Description
	V	Motor phases
	V	
	W	
	PE	Motor earthing ⊕
	⊕	Shield connection at the shield sheet

On double axis devices, there are two of these connections.  
Assignment of the axes:  
 ● Axis "A" = X108  
 ● Axis "B" = X107

Terminal data	Conductor cross-section		Tightening torque		
	[mm <sup>2</sup> ]	[AWG]	[Nm]	[lb-in]	
flexible for the devices E70ACMxx0054xx1xxx E70ACMxx0104xx1xxx E70ACMxx0204xx1xxx E70ACMxx0054xx2xxx E70ACMxx0104xx2xxx E70ACMxx0204xx2xxx E70ACMxx0324xx2xxx	0.2 ... 4	24 ... 12	0.5	4.4	3.5 x 0.6
flexible for the devices E70ACMxx0324xx1xxx E70ACMxx0484xx1xxx E70ACMxx0644xx1xxx	0.5 ... 16	22 ... 6	1.5	13.3	5.5 x 1

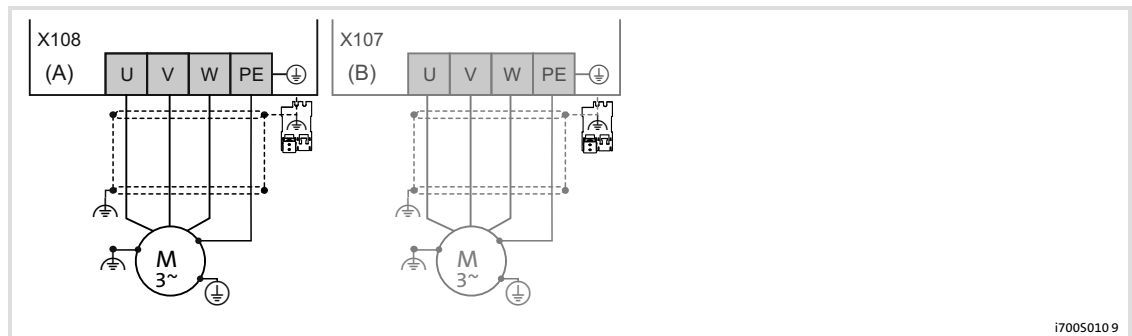

**Fig. 9**      **Wiring of X107 or X108**  
 X107, X108      Connection of motor|s  
 A                    1-axis module: axis A  
 B                    Additionally for 2-axis module: axis B  
 ⊕                    Functional earth ⊕, shield connection



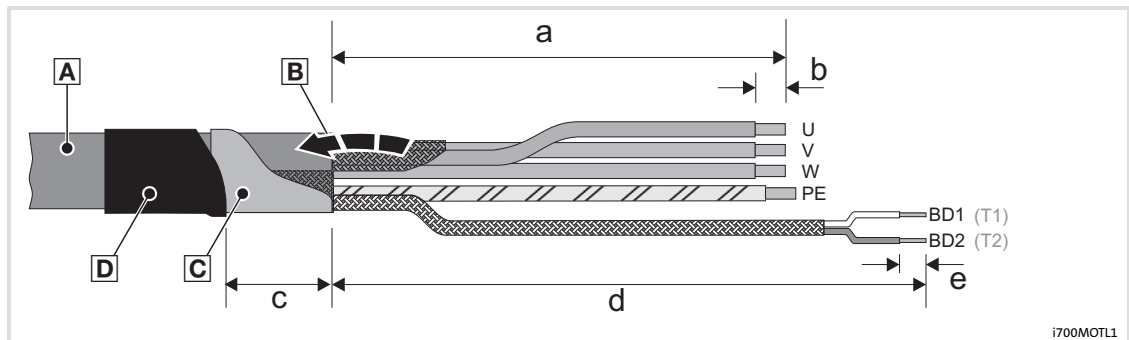

Fig. 4-4 Stripping lengths of the motor cable

	[mm]				
	a	b	c	d	e
E70ACMxxxxx4xx1xxx	180	8	40	210	8
E70ACMxxxxx4xx2xxx	180	8	40	210	8
E70ACMxx0324xx1xxx					
E70ACMxx0484xx1xxx	180	8	40	210	8
E70ACMxx0644xx1xxx					

How to proceed:

1. Strip motor cable **A** as specified.
2. Fold back the shield of the motor cable **B** over the cable sheath.
3. Stabilise the shield with self-adhesive conductive foil **C** (recommendation).
4. Fix the shield and conductive foil with heat-shrinkable tube **D** on the cable sheath.
5. The terminals are directly suitable for the utilisation of flexible conductors. Short circuits between the terminal connections are ruled out by the design if the specified stripping length is met.
  - Wire end ferrules can be used.
  - If insulated wire end ferrules are used, it must be ensured that the effective clamping length is not reduced by the plastic collar.
6. Apply the shields separately on the shield sheet using shield clamps (no strain relief).

## 5 Mechanical installation

### Important notes

## 5 Mechanical installation

### 5.1 Important notes



#### **Danger!**

Sticker with warning note must be displayed prominently and close to the device!



#### **Note!**

The devices must be installed in housings (e.g. control cabinets) to meet applicable regulations.

#### **Summary of important notes on mechanical installation**

- ▶ Mount the devices vertically (📖 30)
  - DC-bus voltage connections (X101/102): at the top
  - Fan unit: at the bottom
- ▶ Observe mounting clearances (📖 30):
  - If unimpeded ventilation of the modules is ensured, the connecting cables can be installed in the mounting clearances
  - The modules can be mounted side-by-side without any clearance
- ▶ Requirements for the mounting and supporting surface to ensure an EMC-compliant installation without the need for additional measures:
  - Electrically conductive
  - Free of lacquer and protected against corrosion or made of rust-proof metal
  - Completely flat and smooth surface
- ▶ In case of push-through installation (thermal separation), the heatsink protrudes through the mounting cutout of the mounting wall.
  - The design of the mounting wall must ensure the tightness towards the device surface.
  - Prevent the mounting wall from being bent or twisted.
- ▶ In order to comply with the permissible pollution degree of the ambient air, (📖 29) provide additional measures:
  - Separate or filtered air flow against dust, fluff, grease, aggressive gas
  - Ensure regular cleaning
- ▶ Observe permissible ambient temperatures - also in the control cabinet (📖 29).

## 5.2 Drilling the holes into the mounting plate

### Mounting grid

We recommend to provide the mounting plate with a grid pattern of M5 threaded holes for attaching the devices. This preparation enables easy attachment of the devices and the device sizes 1 ( $b = 50 \text{ mm}$ ) and 2 ( $b = 100 \text{ mm}$ ) can thus be mounted directly adjacent to each other.



#### Note!

- ▶ M5 screw and washer assemblies or hexagon socket screws with washers are permitted.
- ▶ Tightening torque: 3.4 Nm / 30 lb-in.

## 5 Mechanical installation

### Dimensions

#### Devices with standard built-in design

### 5.3 Dimensions

#### 5.3.1 Devices with standard built-in design

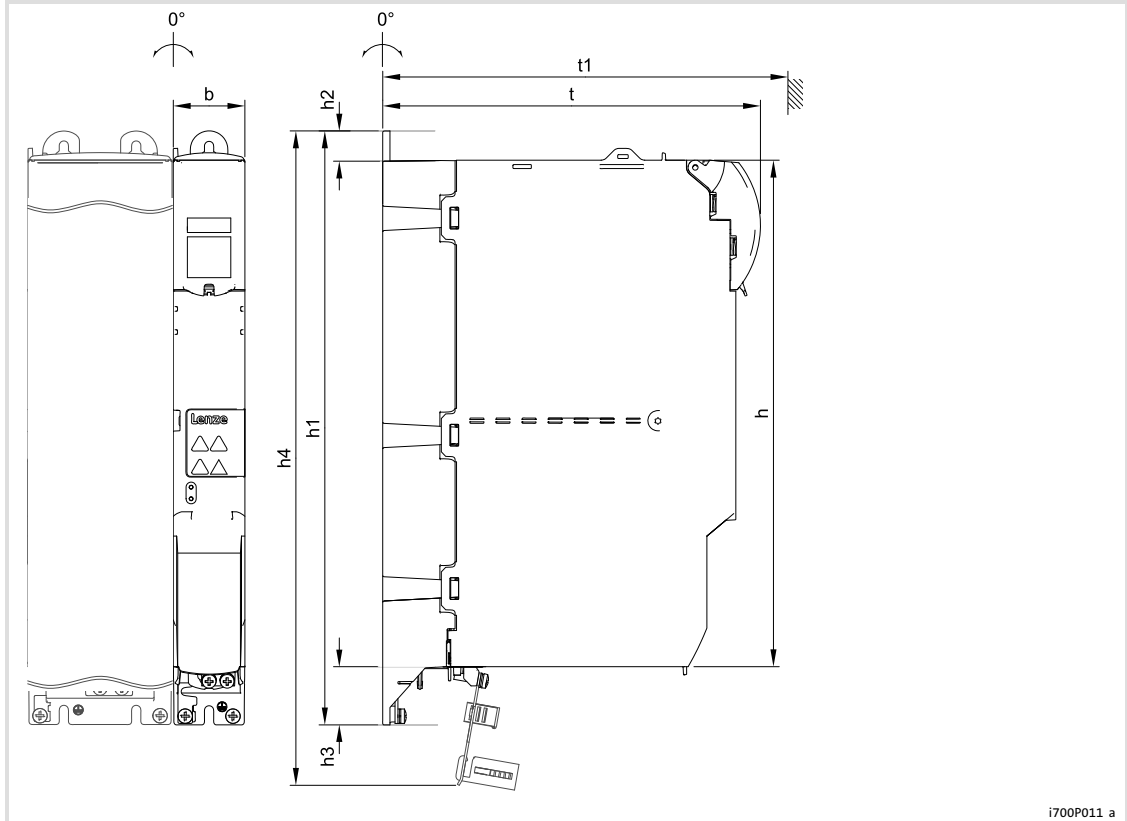

		h	b	t	h1	h2	h3	h4	t1	t2	
	[A]	[mm]									[kg]
E70ACPSE0304x	30	350	50	261	410	20	40	452	275	-	2.5
E70ACPSE0604x	60	350	100	261							5.3
E70ACMxE0054xx1xxx	5	350	50	261	410	20	40	452	275	-	2.7
E70ACMxE0104xx1xxx	10										2.7
E70ACMxE0204xx1xxx	20										2.7
E70ACMxE0054xx2xxx	2 * 5										2.9
E70ACMxE0104xx2xxx	2 * 10	350	100	261	410	20	40	452	275	-	2.9
E70ACMxE0324xx1xxx	32										5.2
E70ACMxE0484xx1xxx	48										5.2
E70ACMxE0644xx1xxx	64										5.2
E70ACMxE0204xx2xxx	2 * 20	350	100	261	410	20	40	452	275	-	5.2
E70ACMxE0324xx2xxx	2 * 32										5.2

5.3.2 Assembly in standard built-in technique

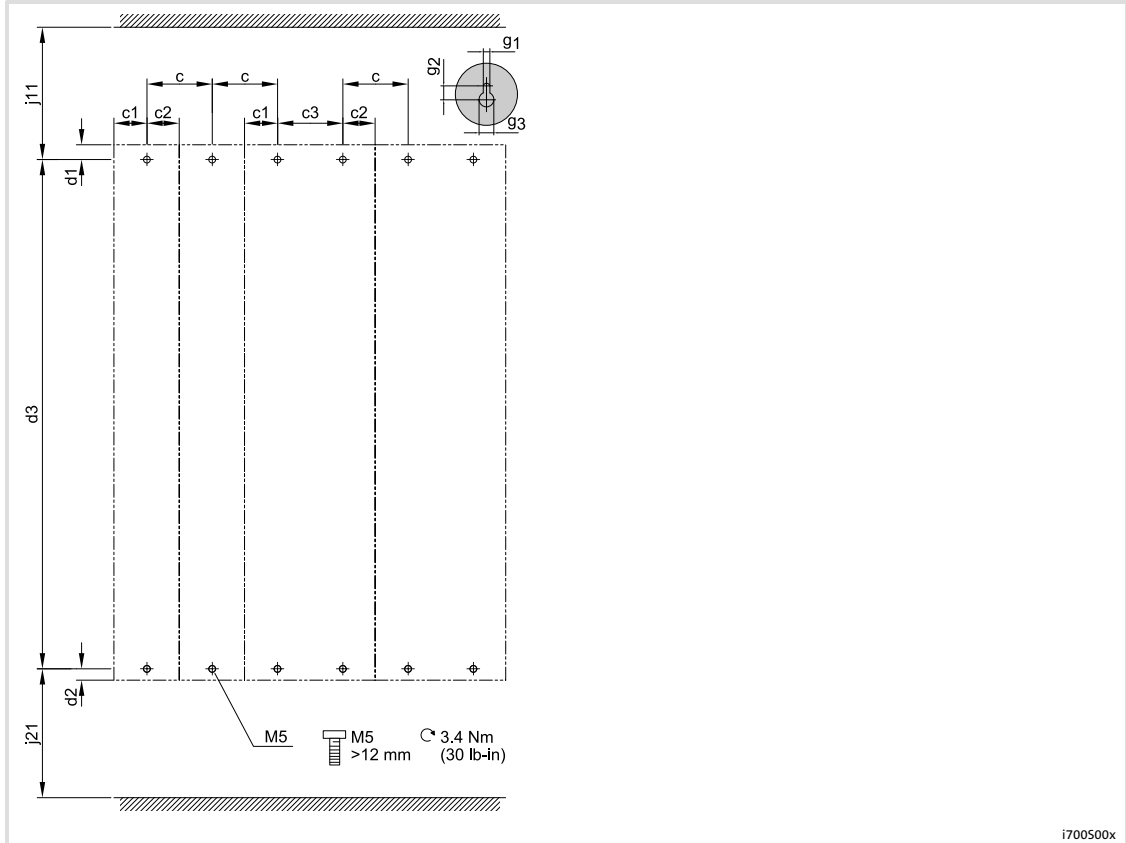

i700500x

		c	c1	c2	c3	d1	d2	d3	j11	j21	g1	g2	g3
	[A]	[mm]											
E70ACPSE0304x	30												
E70ACMxE0054xx1xxx	5												
E70ACMxE0104xx1xxx	10												
E70ACMxE0204xx1xxx	20												
E70ACMxE0054xx2xxx	2*5												
E70ACMxE0104xx2xxx	2*10												
E70ACPSE0604x	60	50	25	25	-	10	10	390	70	90	6	10	15
E70ACMxE0324xx1xxx	32												
E70ACMxE0484xx1xxx	48												
E70ACMxE0644xx1xxx	64				50								
E70ACMxE0204xx2xxx	2*20												
E70ACMxE0324xx2xxx	2*32												

## 5.3.3

## Devices with "cold plate" design

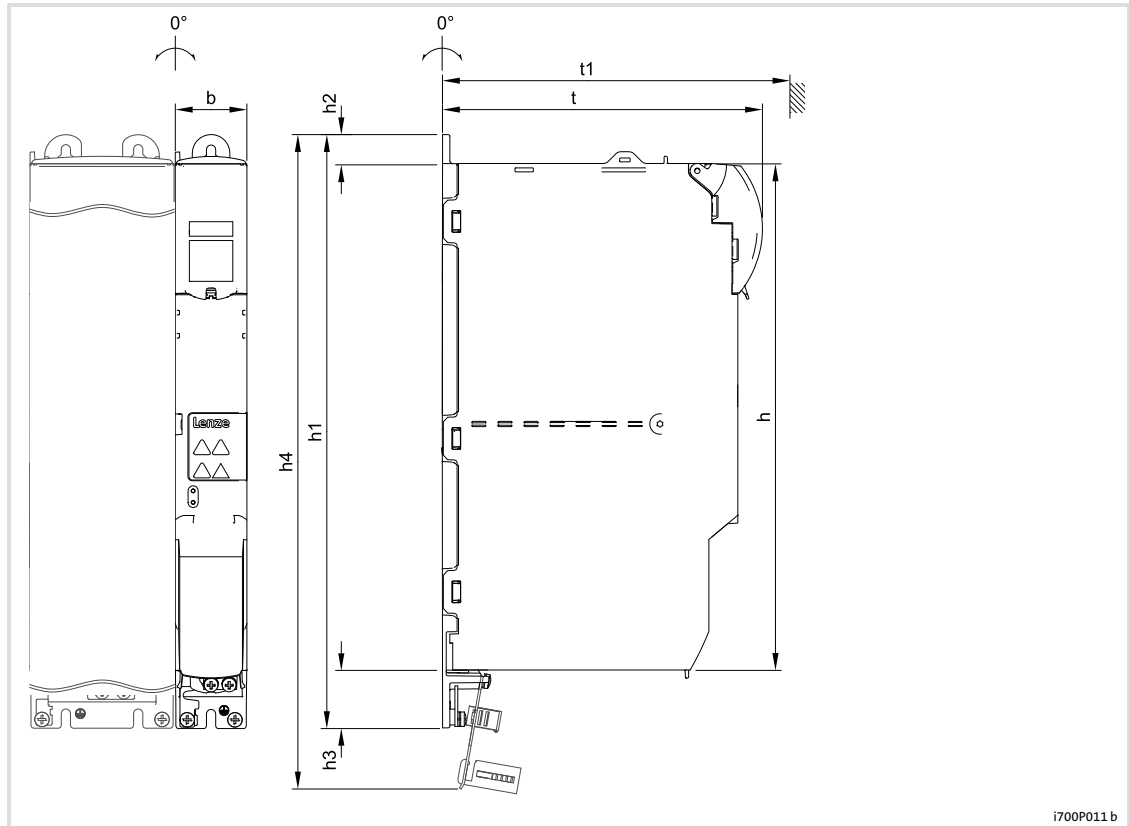

i700P011 b

		h	b	t	h1	h2	h3	h4	t1	t2	
	[A]	[mm]									[kg]
E70ACPSC0304x	30	350	50	221	410	20	40	452	235	-	2.1
E70ACPSC0604x	60	350	100	221							5.4
E70ACMxC0054xx1xxx	5	350	50	221	410	20	40	452	235	-	2.3
E70ACMxC0104xx1xxx	10										2.3
E70ACMxC0204xx1xxx	20										2.3
E70ACMxC0054xx2xxx	2 * 5										2.5
E70ACMxC0104xx2xxx	2 * 10										2.5
E70ACMxC0324xx1xxx	32										5.3
E70ACMxC0484xx1xxx	48	5.3									
E70ACMxC0644xx1xxx	64	350	100	221	410	20	40	452	235	-	5.3
E70ACMxC0204xx2xxx	2 * 20	5.3									
E70ACMxC0324xx2xxx	2 * 32	5.3									

### 5.3.4 Mounting in "cold plate" technique

The E70ACxxCx4x... devices are designed for assembly on coolers (e.g. collective coolers) in "cold-plate" technique.

#### Requirements for collective coolers

A good thermal connection to the cooler is important for the trouble-free operation of the controller:

- ▶ The contact area between the collective cooler and the controller
  - must be at least as big as the cooling plate of the controller.
  - must be smooth, the maximum deviation must not exceed 0.05 mm.
- ▶ The controller has to be connected to the collective cooler with all required screwed joints.
- ▶ The thermal resistance  $R_{th}$  must be observed, see table.  
The values in the table apply to the operation of the controllers under rated conditions.  
The values already include the heat transmission between the cooler and the device with a standard heat conducting paste at a film thickness of approx. 50  $\mu\text{m}$ .

Type	Power loss	Thermal resistance	$T_{max}$	Power loss (control cabinet)
	$P_{V1}$ [W]	$R_{th}$ [K/W]	[°C]	$P_{V2}$ [W]
E70ACPSC0304x	45	$\leq 1.11$	85	15
E70ACMxC0054xx1xxx	25	$\leq 2.00$	85	25
E70ACMxC0104xx1xxx	50	$\leq 1.00$	85	30
E70ACMxC0204xx1xxx	95	$\leq 0.53$	85	35
E70ACMxC0054xx2xxx	50	$\leq 1.00$	85	40
E70ACMxC0104xx2xxx	95	$\leq 0.53$	85	55
E70ACPSC0604x	85	$\leq 0.41$	70	25
E70ACMxC0324xx1xxx	140	$\leq 0.29$	75	70
E70ACMxC0484xx1xxx	215	$\leq 0.19$	75	85
E70ACMxC0644xx1xxx	290	$\leq 0.14$	75	100
E70ACMxC0204xx2xxx	185	$\leq 0.22$	75	75
E70ACMxC0324xx2xxx	275	$\leq 0.15$	75	105

Tab. 5-1 Cold plate

$P_{V1}$  separated power loss, to be dissipated via heatsink  
 $P_{V2}$  Power loss remaining in the control cabinet

#### Ambient conditions

- ▶ The rated data and the derating factors at increased temperature also apply to the ambient temperature of the drive controllers.



#### Note!

Apply standard heat-conducting paste or heat-conducting foil onto cooler and cooling plate before you bolt the controller onto the cooler.

# Mechanical installation

## Dimensions

### Mounting in "cold plate" technique

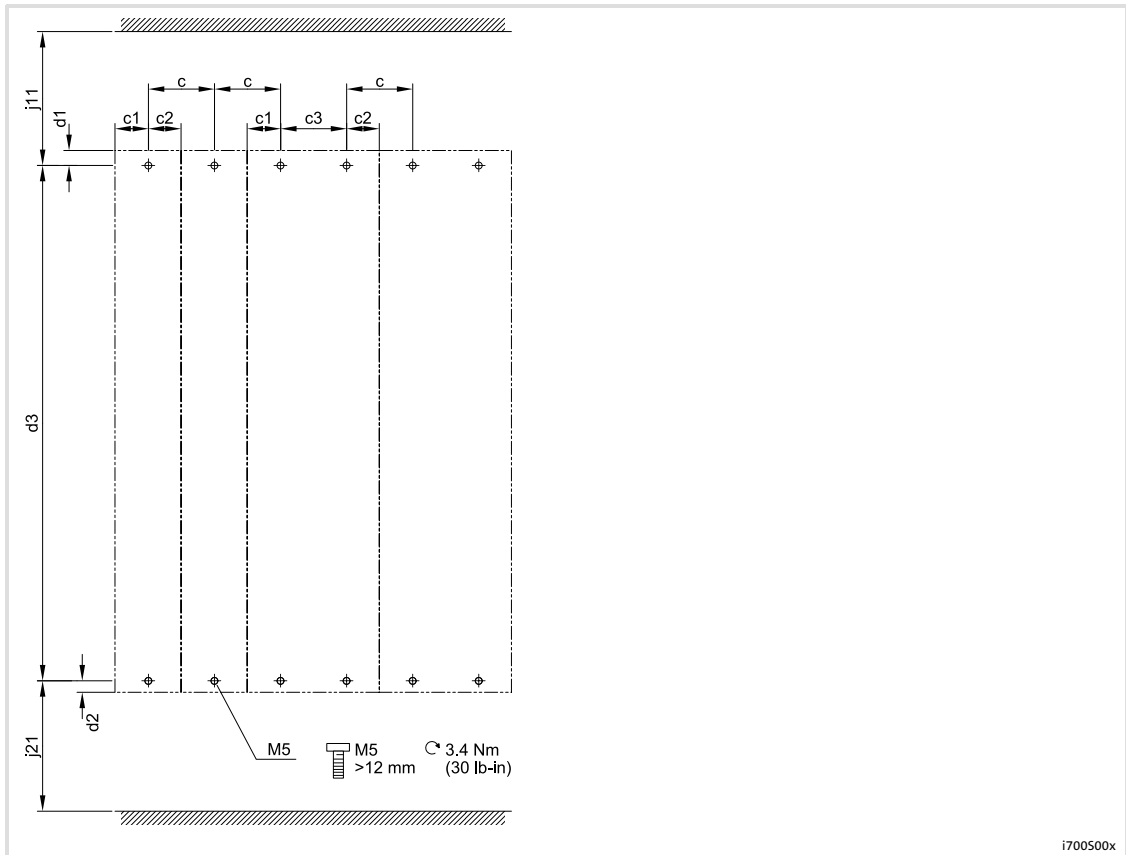

i700500x

		c	c1	c2	c3	d1	d2	d3	j11	j21
	[A]	[mm]								
E70ACPSC0304x	30	50	25	25	50	10	10	390	90	70
E70ACMxC0054xx1xxx	5									
E70ACMxC0104xx1xxx	10									
E70ACMxC0204xx1xxx	20									
E70ACMxC0054xx2xxx	2*5									
E70ACMxC0104xx2xxx	2*10									
E70ACPSC0604x	60									
E70ACMxC0324xx1xxx	32									
E70ACMxC0484xx1xxx	48									
E70ACMxC0644xx1xxx	64									
E70ACMxC0204xx2xxx	2*20									
E70ACMxC0324xx2xxx	2*32									



**Safety instructions for the installation according to UL****Original - English****Warnings!**

- ▶ The device should be mounted in an overall enclosure with proper spacings being maintained.
- ▶ The terminals are suitable for factory and field wiring connection when the suitability of the intended mating connection has been determined.
- ▶ All Cold Plate devices E70ACPxC... and E70ACMxC... are intended to be mounted with adequate heat sink assemblies in the end use.
- ▶ In Order to determine the acceptability of these assemblies , a temperature test shall be considered in the end use. The temperature on the heat sinks shall not exceed the values listed in Tab. 5-1.

Original - French

**Avertissement !**

- ▶ Les équipements doivent être montés dans un coffret de protection adapté en respectant les espaces minimums prescrits.
- ▶ Les terminaux sont adaptés à un câblage en usine et à pied d'œuvre à condition que les raccords de destination soient compatibles.
- ▶ Tous les appareils de type Cold Plate E70ACPxC... et E70ACMxC... sont destinés à être montés en combinaison avec un radiateur adapté en vue de l'application finale.
- ▶ Afin de déterminer l'admissibilité de ces combinaisons, procéder à un test de température dans le cadre de l'application finale. La température des radiateurs ne doit pas dépasser les valeurs figurant dans le tableau Tab. 5-1.

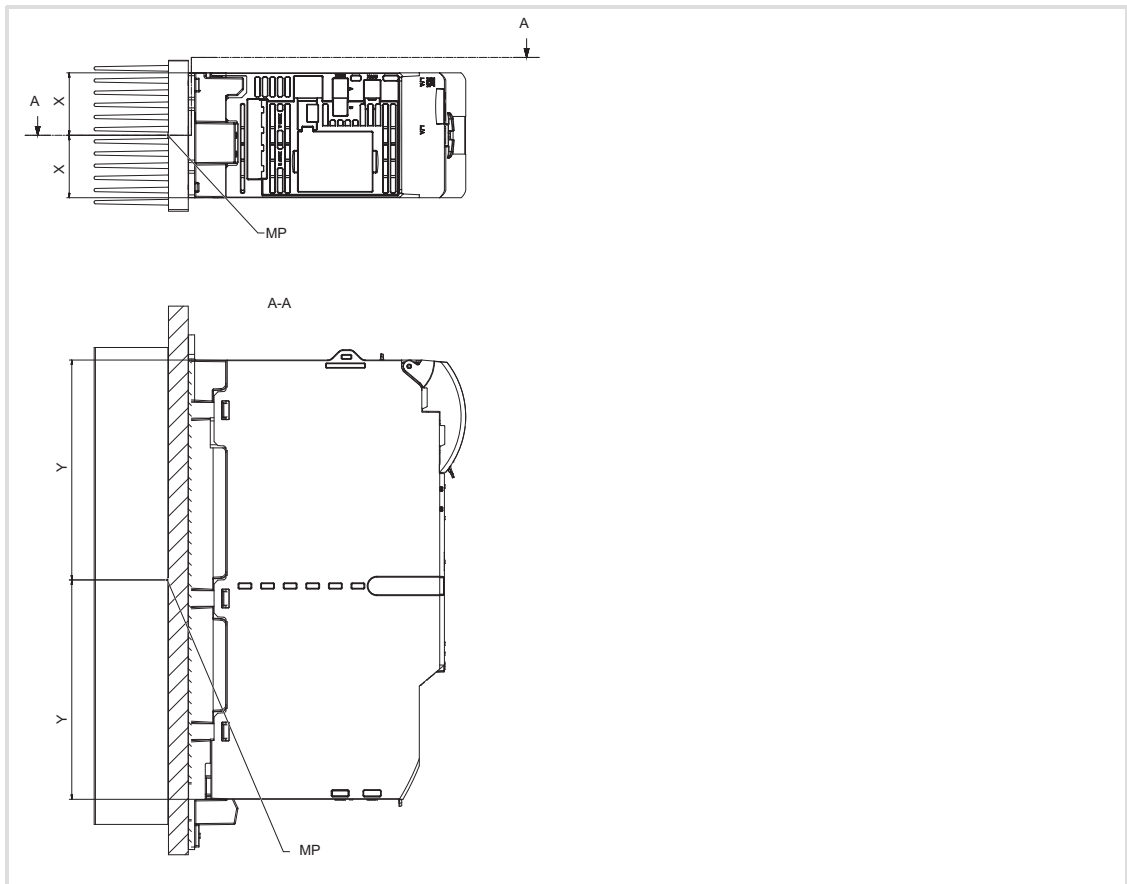

Fig. 5-1 Position of the measuring points (MP)



# 5 Mechanical installation

## Devices with push-through design

### 5.3.5 Devices with push-through design

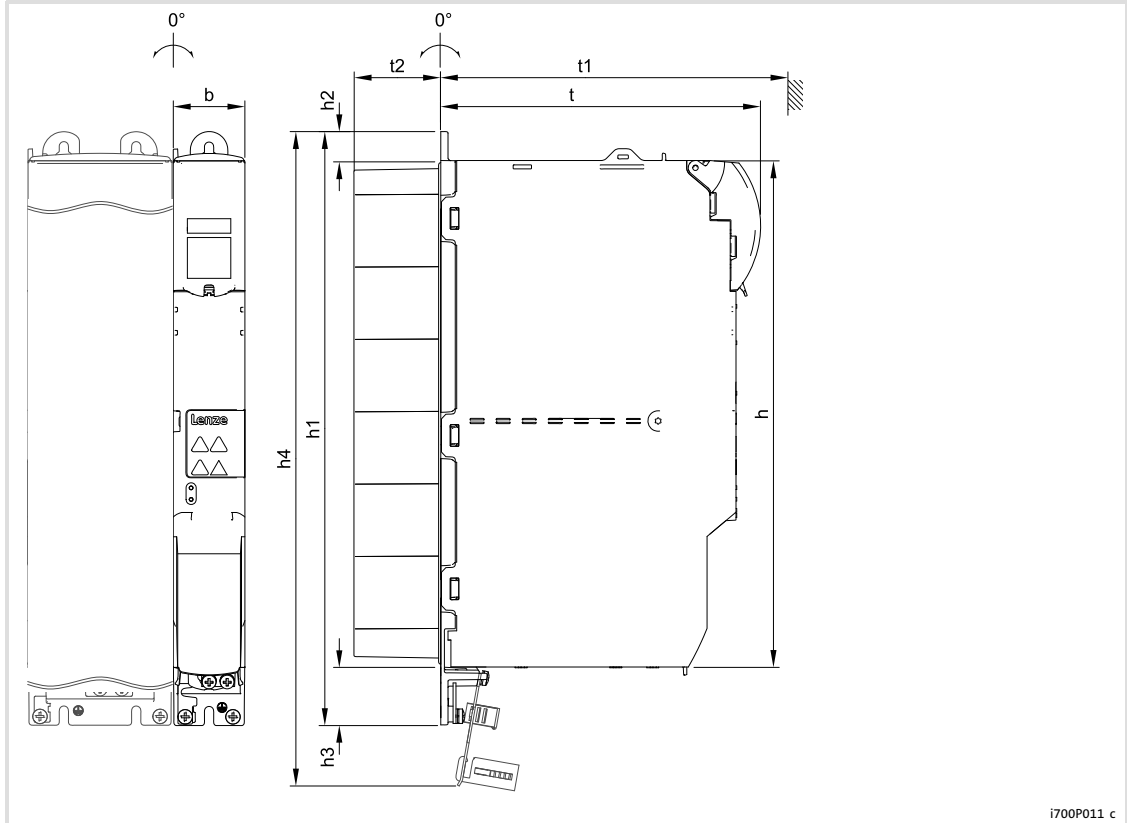

		h	b	t	h1	h2	h3	h4	t1	t2	
	[A]	[mm]									[kg]
E70ACPSD0304x	30	350	50	221	410	20	40	452	235	60	2.8
E70ACPSD0604x	60	350	100	221							7.3
E70ACMxD0054xx1xxx	5	350	50	221	410	20	40	452	235	60	3.0
E70ACMxD0104xx1xxx	10										3.0
E70ACMxD0204xx1xxx	20										3.0
E70ACMxD0054xx2xxx	2 * 5										3.2
E70ACMxD0104xx2xxx	2 * 10										3.2
E70ACMxD0324xx1xxx	32										7.1
E70ACMxD0484xx1xxx	48	7.1									
E70ACMxD0644xx1xxx	64	350	100	221	410	20	40	452	235	60	7.1
E70ACMxD0204xx2xxx	2 * 20	7.1									
E70ACMxD0324xx2xxx	2 * 32	7.1									

## Assembly in push-through technique (thermal separation)

## 5.3.6 Assembly in push-through technique (thermal separation)

**Note!**

The installation must ensure the required tightness.

For this purpose, the mounting plate with the required cutouts must have a sufficient rigidity against the seal.

Overview of the mechanical requirements of the mounting position:

**Requirements**

## Cutouts

Tolerance	± 0.5 mm
Corner radius R	1 ... 2 mm
Evenness to the seal	0.5 mm

## Fixing holes

Tolerance	± 0.25 mm
Seal	Use thread sealant

## Bar reinforcement (suggestion)

Flat material	5 * 20 * 400 mm
---------------	-----------------

Type	Power loss	
	P <sub>V1</sub> [W]	P <sub>V2</sub> [W]
E70ACPSD0304x	60	20
E70ACMxD0054xx1xxx	30	20
E70ACMxD0104xx1xxx	50	30
E70ACMxD0204xx1xxx	100	30
E70ACMxD0054xx2xxx	60	30
E70ACMxD0104xx2xxx	100	50
E70ACPSD0604x	130	30
E70ACMxD0324xx1xxx	160	50
E70ACMxD0484xx1xxx	230	70
E70ACMxD0644xx1xxx	310	80
E70ACMxD0204xx2xxx	200	60
E70ACMxD0324xx2xxx	310	70

P<sub>V1</sub>P<sub>V2</sub>

separated power loss, to be dissipated via heatsink

Power loss remaining in the control cabinet

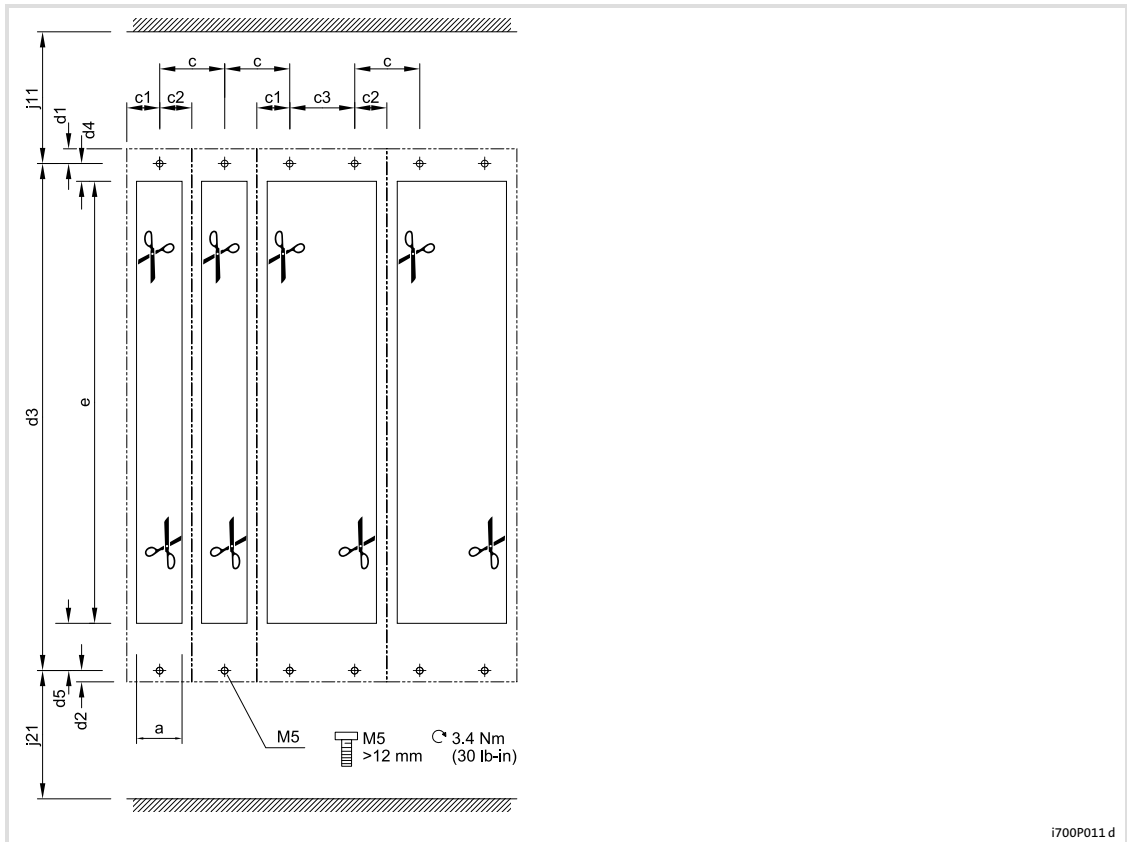

	a	e	c	c1	c2	c3	d1	d2	d3	d4	d5	j11	j21
[A]	[mm]												
E70ACPSD0304x	30												
E70ACMxD0054xx1xxx	5												
E70ACMxD0104xx1xxx	10												
E70ACMxD0204xx1xxx	20												
E70ACMxD0054xx2xxx	2*5												
E70ACMxD0104xx2xxx	2*10												
E70ACPSD0604x	60	340	50	25	25		10	10	390	15	35	90	70
E70ACMxD0324xx1xxx	32												
E70ACMxD0484xx1xxx	48												
E70ACMxD0644xx1xxx	64												
E70ACMxD0204xx2xxx	2*20												
E70ACMxD0324xx2xxx	2*32												

#### 5.4 Notes on mounting the device version in push-through design

In case of compactly designed control cabinets, special attention has to be paid to the dissipation of the power loss.

The device version in push-through design (E70ACxxD...) serves to separate the heatsink losses from the other device losses and dissipate them from the control cabinet. This serves to reduce the temperature inside the control cabinet. The thermal load of all components is reduced and the reliability of the plant is improved.

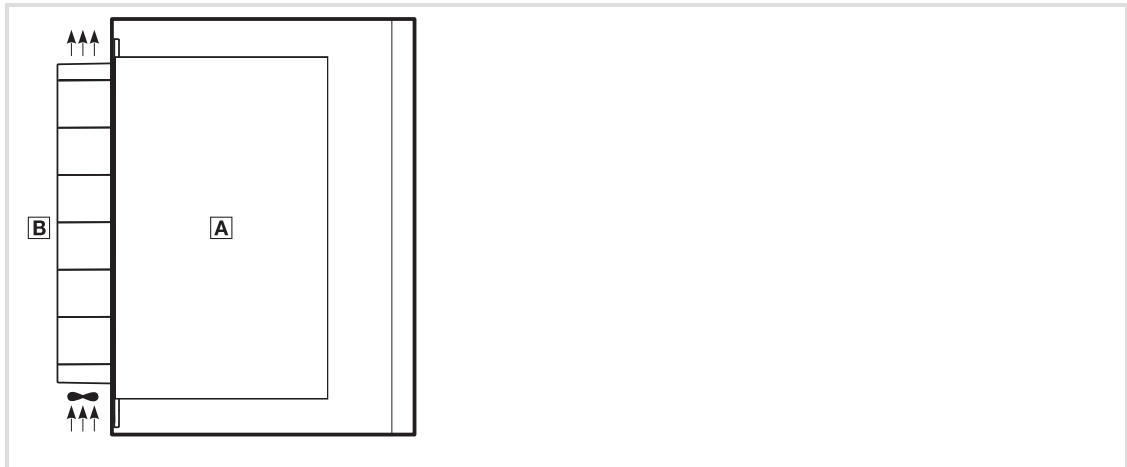

Fig. 5-2 Basic arrangement of the thermal separation using the push-through technique

- ▣ A Controller in the control cabinet
- ▣ B Heatsink separated from the control cabinet volume

### All about cooling

A good cooling is achieved by a focussed air flow at the cooling ribs.

By measuring the air speed, the compliance with the required cooling should be checked. The measurement has to be executed at the points (MP) defined in the illustration for the heatsink cross-section.

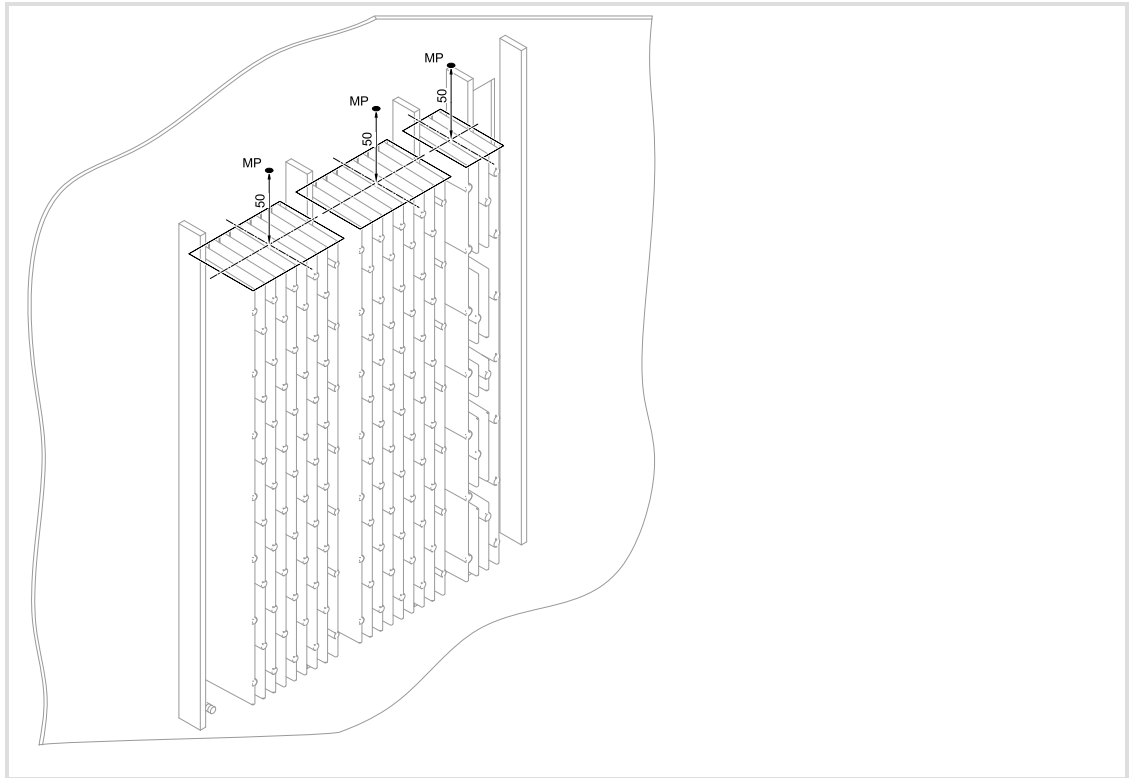

Fig. 5-3 Positions of the measuring points, centrally above the heatsink

If a single fan is to cool several devices, this fan has to provide the sum of all volume flows.



### Tip!

An air channel serves to implement a protection against accidental contact towards the hot heatsink surface.

An air channel provides a sufficient air flow for each device.



**Cooling by forced ventilation**

Required:

- ▶ Forced ventilation by one or several fans.
- ▶ Air speed: 2.5 m/s at the MP measuring point
  - For fan dimensioning: Corresponds to a volume flow of 0.5 m<sup>3</sup>/min (17.6 CFM) per 50 mm device installation width.

Permissible:

- ▶ Operation with continuous output current  $I_a = I_{rated}$ .
- ▶ Operation according to rated data.
- ▶ Switching frequencies  $f_{ch}$ : 4 kHz, 8 kHz and 16 kHz

**Cooling by means of natural convection**

Required:

- ▶ Unhindered ventilation by means of natural convection (no fan required).
- ▶ Ambient temperature:  $T_{amb} < 40\text{ °C}$

Permissible:

- ▶ Operation with reduced output current  $I_a$  according to Tab. 5-2.
- ▶ Switching frequencies  $f_{ch} = 4\text{ kHz}$  and  $8\text{ kHz}$

Type	$I_a$ [A]		
E70ACPxD0304x	25		
E70ACPxD0604x	50		

Type	$I_a$ [A]		
	4 kHz	8 kHz	16 kHz
E70ACMxD0054xx1ETx	2.5	2.5	
E70ACMxD0104xx1ETx	5.0	5.0	
E70ACMxD0204xx1ETx	6.0	6.0	
E70ACMxD0054xx2ETx	2 x 2.5	2 x 2.5	
E70ACMxD0104xx2ETx	∑ 5.0	∑ 5.0	
E70ACMxD0324xx1ETx	12.0	9.6	
E70ACMxD0484xx1ETx	14.0	11.2	
E70ACMxD0644xx1ETx	16.0	12.8	
E70ACMxD0204xx2ETx	∑ 10.0	∑ 10.0	
E70ACMxD0324xx2ETx	∑ 12.0	∑ 9.6	

Tab. 5-2 Permissible currents  $I_a$  in case of natural convection

∑ Sum of the output currents axis A and axis B

## Mechanical installation

Notes on mounting the device version in push-through design  
 Assembly in push-through technique (thermal separation)

### Suitable mounting place

Providing a wide contact area and the integrated seal, the mounting area of the device complies with the requirements of the class of protection IP54. The mounting has to be carried out properly at a mounting position with sufficient rigidity. The "mounting frame" accessories serve to achieve the sufficient rigidity more easily.

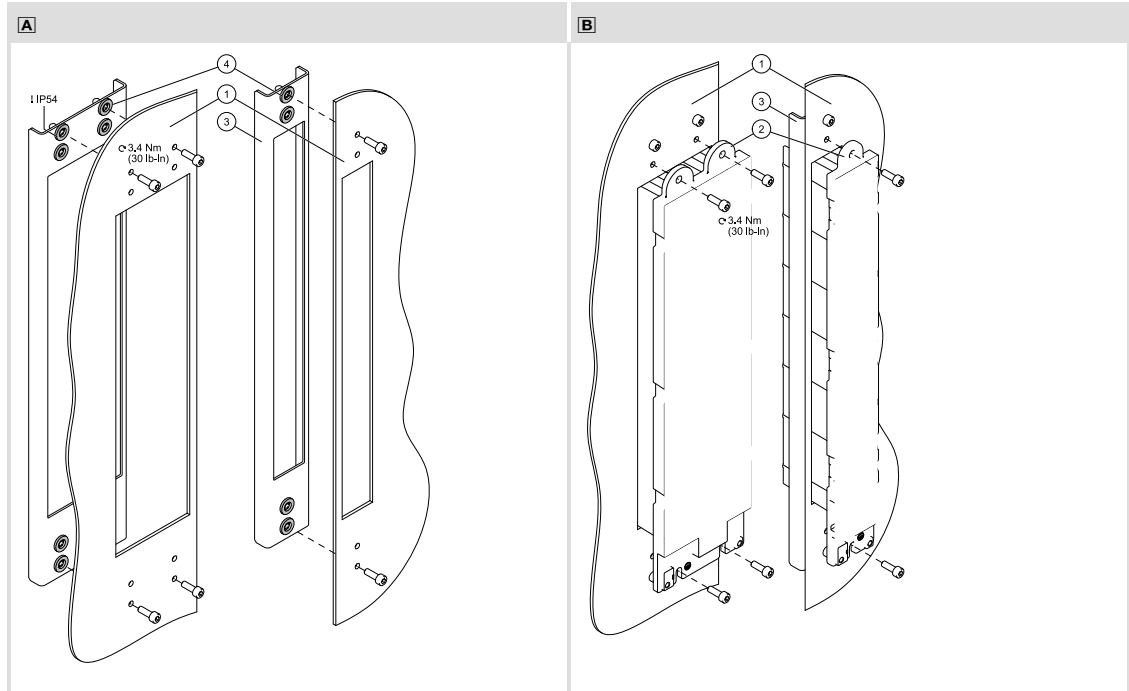

Example for achieving rigidity of the mounting position with E70AZMBHM00x mounting frame

- A** Step 1: Mounting of the frames
- B** Step 2: Mounting of the devices

Bars attached on the sides of the mounting cutouts are an option to achieve the required rigidity.

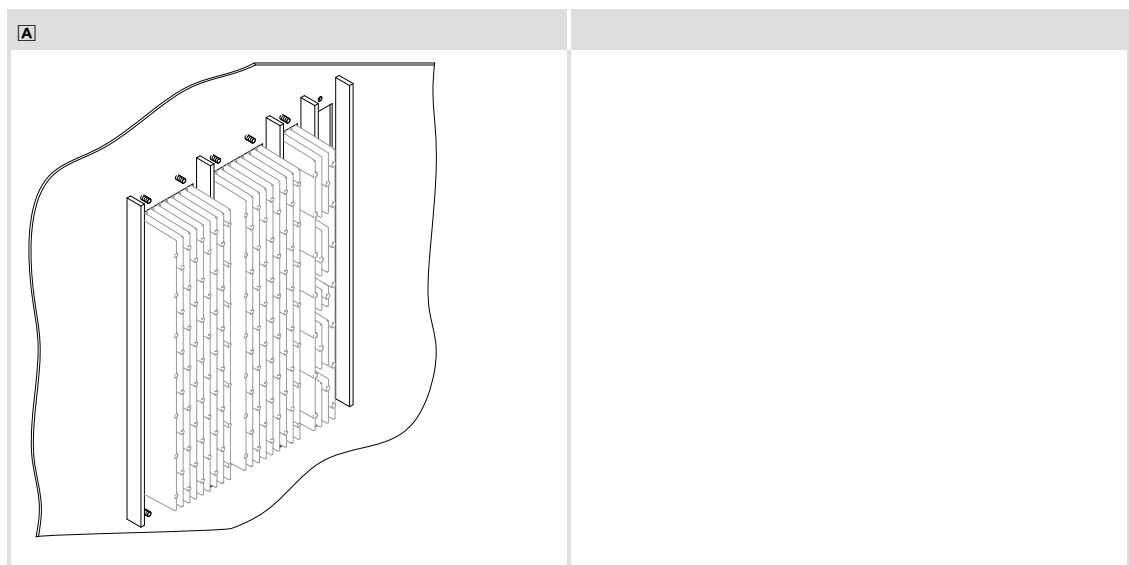

- A** Example for achieving rigidity of the mounting position with bars

**Safety instructions for the installation according to UL**

If a control cabinet/plant is to be approved according to UL, the following has to be considered:

- ▶ The device version in "push-through design" is made for the installation in the control cabinet and achieves "Open Type" according to UL508C.
- ▶ If the cooling ribs are not inside the control cabinet but stick out of the control cabinet housing: Prevent direct contact with the cooling ribs.

## Original - English

**Warnings!**

- ▶ The device should be mounted in an overall enclosure with proper spacings being maintained.
- ▶ The terminals are suitable for factory and field wiring connection when the suitability of the intended mating connection has been determined.
- ▶ Pusch-trough devices E70ACPxD... and E70ACMxD..., which are intended to be used with external forced ventilation or natural convection.
- ▶ Forced ventilation:
  - Ratings at surrounding air temperature of max. 40 °C or with reduced ratings at max. 55 °C.
  - Only valid when provided with additional external forced cooling as specified in the hardware manual.
- ▶ Natural convection:
  - Reduced ratings at surrounding air temperature of max. 40 °C.
  - No external forced cooling is required.

Original - French



### **Avertissement !**

- ▶ Les équipements doivent être montés dans un coffret de protection adapté en respectant les espaces minimums prescrits.
- ▶ Les terminaux sont adaptés à un câblage en usine et à pied d'œuvre à condition que les raccords de destination soient compatibles.
- ▶ Relier les appareils de type E70ACPxD... et E70ACMxD..., destinés à être utilisés avec un système de ventilation forcée externe ou à convection naturelle.
- ▶ Ventilation forcée :
  - Caractéristiques assignées valables pour une température ambiante maximale de 40 °C ou de 55 °C avec des valeurs réduites.
  - Convient uniquement si associée à un système de refroidissement forcé externe, conformément aux spécifications contenues dans la documentation de l'équipement.
- ▶ Convection naturelle :
  - Valeurs assignées réduites valables pour une température ambiante maximale de 40 °C.
  - Système de refroidissement forcé externe non requis.

## 6 Electrical installation

Important notes

## 6 Electrical installation

### 6.1 Important notes



#### **Stop!**

The device contains components that can be destroyed by electrostatic discharge!

Before working on the device, the personnel must ensure that they are free of electrostatic charge by using appropriate measures.



#### **Danger!**

##### **Dangerous voltage**

The leakage current to earth (PE) is  $> 3.5$  mA AC or  $> 10$  mA DC.

##### **Possible consequences:**

- ▶ Death or severe injuries when the device is touched in the event of a fault.

##### **Protective measures:**

- ▶ Implement the actions required in the EN 61800-5-1. Especially:
  - Fixed installation
  - PE connection must conform to standards (PE conductor diameter  $\geq 10$  mm<sup>2</sup> or PE conductor must be connected twice)



#### **Danger!**

##### **Hazardous electrical voltage**

All power connections carry a hazardous electrical voltage for a longer time after mains disconnection. Observe the information regarding the discharge time on the device.

##### **Possible consequences:**

- ▶ Death or severe injuries when touching the power terminals.

##### **Protective measures:**

- ▶ Before working on the power connections, wait at least until the discharge time has passed (depending on the device, this may be up to 30 minutes).
- ▶ Make sure that all power terminals are deenergised.

### 6.1.1 Electrical isolation

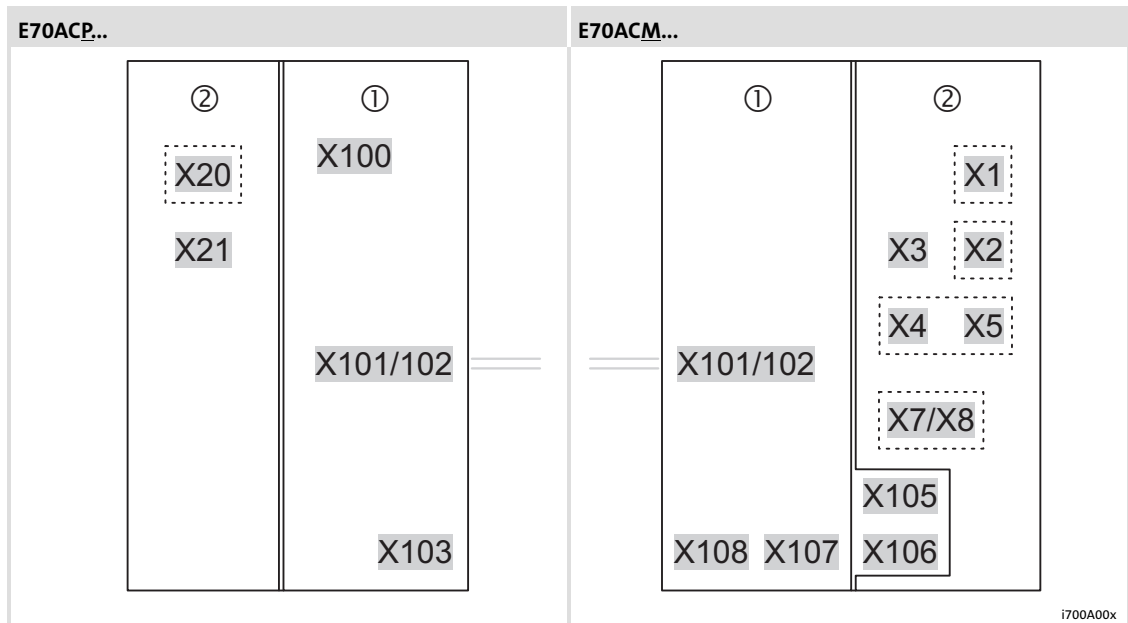

i700A00x

#### Legend

⋮	Isolation by functional insulation
	Isolation by basic insulation
	Safe isolation by double or reinforced insulation Protection against accidental contact is guaranteed without any further measures.

E70ACP...	Power supply module	E70ACM...	Axis module
①	Power section	①	Power section
②	Control section	②	Control section
		X1	Safety system
X20	Digital inputs and outputs	X2	Digital inputs
X21	24-V voltage supply	X3	24-V voltage supply
X100	AC mains		
X101/102	DC bus +UG/-UG	X101/102	DC bus +UG/-UG
X103	Brake resistor		
		X4/X5	EtherCAT
		X7/X8	Resolver or encoder
		X105	24-V voltage supply of motor holding brake
		X106	Motor holding brake
		X107	Motor B
		X108	Motor A

### 6.1.2 Device protection

The trouble-free operation of power supply modules with an external brake resistor is only ensured if an axis module is installed in the immediate vicinity. Preferably by end-to-end mounting and use of the DC busbar system (X101/X102).

- ▶ In case of condensation, do not connect the controller to the mains voltage before the moisture has evaporated completely.
- ▶ Provide unused control inputs and outputs with terminal strips.

**6.1.3****Motor protection**

- ▶ Extensive protection against overload by means of temperature monitoring:
  - with KTY or PTC sensors of the resolvers or encoders
  - with activated  $I^2t$  monitoring
  - Combination of the possible monitoring modes
- ▶ Only use motors which have a suitable insulation for the inverter operation:
  - Insulation resistance: min.  $\hat{u} = 1.5 \text{ kV}$ , min.  $du/dt = 5 \text{ kV}/\mu\text{s}$
  - When using motors with an unknown insulation resistance, please contact your motor supplier.

**6.1.4****Interaction with compensation equipment**

- ▶ Drive control systems only consume very little fundamental reactive power from the supplying AC system. Therefore, compensation is not required.
- ▶ If the drive control systems are operated on supply systems by means of compensation equipment, the compensation equipment must include chokes.
  - For this purpose, please contact the supplier of the compensation equipment.



## 6.2 Safety instructions for the installation according to UL/CSA

### Original - English



#### Warnings!

- ▶ Use 60/75 °C copper wire only, except for control circuits.
- ▶ Suitable for use in a surrounding air temperature of 40 °C, and additionally 55 °C when the derating rules are followed.
- ▶ Voltage of the fuses must at least be suitable for the input voltage of the drive.
- ▶ The opening of branch circuit protective device may be an indication that a fault has been interrupted. To reduce the risk of fire or electric shock, current-carrying parts and other components of the controller should be examined and replaced if damaged.
- ▶ For E70ACPS0304x AC/DC power supply module only:
  - Suitable for use on a circuit capable of delivering not more than 100 k rms symmetrical amperes, 480 V max,
  - when protected by class J, T or G fuses or protected by a circuit breaker having an interrupting rating not less than 100 k rms symmetrical amperes, 480 V.
  - Use fuses or circuit breakers only.
- ▶ For E70ACPS0604x AC/DC power supply module only:
  - Suitable for use on a circuit capable of delivering not more than 100 k rms symmetrical amperes, 480 V max,
  - when protected by class J, T or G fuses.
  - Use fuses only.
- ▶ E70ACMxxxxx4x... DC/AC inverter units:
  - The integral solid state protection does not provide branch circuit protection. Branch circuit protection has to be provided externally in accordance with the National Electrical Code and any additional codes.
- ▶ E70ACMxxxxx4x... DC/AC inverter units, connected to an external DC power supply:
  - Overload protection: 125 % of rated FLA

**Warnings!****Conditions of acceptability:**

- ▶ The device should be mounted in an overall enclosure with proper spacings being maintained.
- ▶ The terminals are suitable for factory and field wiring connection when the suitability of the intended mating connection has been determined.
- ▶ The devices E70AC followed by one digit, followed by C, followed by suffixes are intended to be mounted with adequate heat sink assemblies. In order to determine the acceptability of these assemblies, the equipment shall be subjected to temperature tests.

Temperature tests are conducted with the following aluminum heat sinks:

- Units size 1: Heat sink size 410 mm by 50 mm by 80 mm.
  - Units size 2: Heat sink size 410 mm by 100 mm by 90 mm.
- ▶ The heat sinks of devices E70AC followed by one digit, followed by D, followed by suffixes are intended to be ventilated adequately. In order to determine the acceptability of these assemblies, the equipment shall be subjected to temperature tests.

Original - French

**Avertissement !**

- ▶ Utiliser exclusivement des conducteurs cuivre 60/75 °C, sauf pour la partie commande.
- ▶ Supporte une température ambiante de 40 °C ou 55 °C avec réduction de puissance.
- ▶ La tension des fusibles doit être adaptée à la tension d'entrée de l'entraînement.
- ▶ Le déclenchement du dispositif de protection du circuit de dérivation peut être dû à une coupure qui résulte d'un courant de défaut. Pour limiter le risque d'incendie ou de choc électrique, examiner les pièces porteuses de courant et les autres éléments du contrôleur et les remplacer s'ils sont endommagés.
- ▶ Module d'alimentation CA/CC E70ACPS0304x uniquement :
  - Convient aux circuits non susceptibles de délivrer plus de 100 k ampères symétriques eff., maximum 480 V,
  - avec protection par des fusibles de calibre J, T ou G ou par un disjoncteur à pouvoir de coupure nominal d'au moins 100 k ampères symétriques eff., maximum 480 V.
  - Utiliser exclusivement des fusibles ou des disjoncteurs.
- ▶ Module d'alimentation CA/CC E70ACPS0604x uniquement :
  - Convient aux circuits non susceptibles de délivrer plus de 100 k ampères symétriques eff., maximum 480 V,
  - avec protection par des fusibles de calibre J, T ou G.
  - Utiliser exclusivement des fusibles.
- ▶ Variateurs E70ACMxxxxx4x... CC/CA :
  - La protection statique intégrée n'offre pas la même protection qu'un disjoncteur. Une protection par disjoncteur externe doit être fournie, conformément au National Electrical Code et aux autres dispositions applicables.
- ▶ Variateurs CC/CA E70ACMxxxxx4x... reliés à une source d'alimentation CC externe :
  - Protection contre les surcharges : 125 % de l'intensité nominale à pleine charge

**Avertissement !****Conditions d'acceptabilité :**

- ▶ L'appareil doit être monté dans une enveloppe de protection en respectant les espacements minimums prescrits.
- ▶ Les bornes sont compatibles avec des raccordements extérieurs et en usine, l'adéquation du mode de raccordement envisagé devant être établie.
- ▶ Les appareils de type E70AC dont la référence est suivie d'un chiffre, de la lettre C et de suffixes doivent être dotés des radiateurs appropriés. Afin d'établir si ces entités remplissent les conditions d'acceptabilité, il convient de soumettre l'équipement à des tests de température.

Les tests de température sont menés sur les radiateurs en aluminium suivants :

- Dimensions module 1 : radiateur 410 mm x 50 mm x 80 mm.
- Dimensions module 2 : radiateur 410 mm x 100 mm x 90 mm.
- ▶ Les radiateurs des appareils de type E70AC dont la référence est suivie d'un chiffre, de la lettre D et de suffixes doivent être ventilés de façon appropriée. Afin d'établir si ces entités remplissent les conditions d'acceptabilité, il convient de soumettre l'équipement à des tests de température.

### 6.3 Installation according to EMC (installation of a CE-typical drive system)

#### Design of the cables

- ▶ The cross-section of the PE conductor must be dimensioned according to the relevant national regulations.
- ▶ The cables used must comply with the approvals required for the location (e.g. UL).

#### 6.3.1 Shielding

##### Requirements

- ▶ The effectiveness of a shielded cable is reached by:
  - Providing a good shield connection through large-surface shield contact.
  - Using only braided shields with low shield resistance made of tin-plated or nickel-plated copper braid.
  - Using braided shields with an overlap rate > 70 % and an overlap angle of 90 °.
  - Keeping unshielded cable ends as short as possible.

Use system cables or shielded cables for these connections:

- ▶ Motor
- ▶ Feedback systems
- ▶ Motor holding brake (shielding is required when being integrated into the motor cable; connection to optional motor brake control)

The following connections need not be shielded:

- ▶ 24 V supply
- ▶ Digital signals (inputs and outputs)

##### Connection system

- ▶ Connect the shield with a large surface and fix it with metal cable binders or a conductive clamp. (📖 11.9)
- ▶ Connect the shield directly to the corresponding device shield sheet.
  - If required, additionally connect the shield to the conductive and earthed mounting plate in the control cabinet.
  - If required, additionally connect the shield to the cable clamp rail.

## Realisation

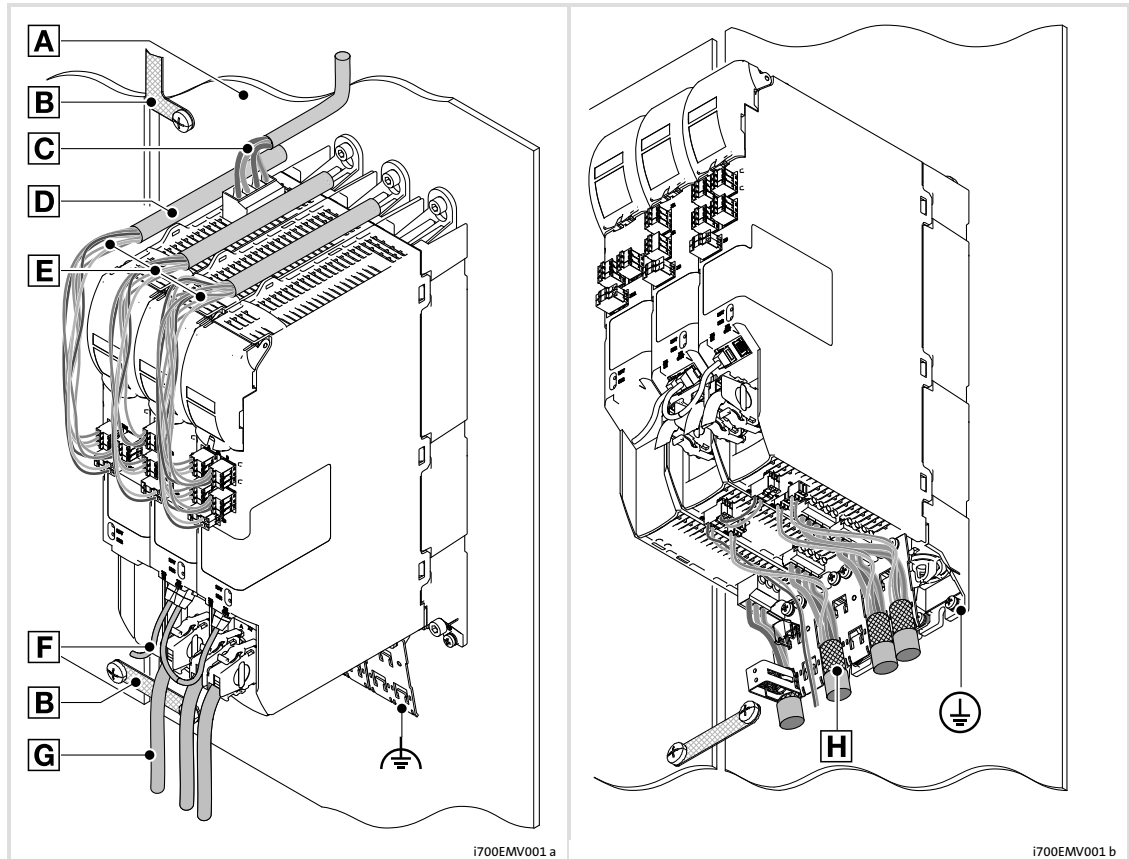

Fig. 6-1 Wiring in compliance with EMC standards

- Ⓐ Mounting plate with electrically conductive surface
- Ⓑ Earth connection of the control cabinet elements
- Ⓒ Mains connection, unshielded cable
- Ⓓ Bundling of cables in the conduit
- Ⓔ Control cables and supply voltage, unshielded
- Ⓕ System cables, EtherCAT® communication bus (scope of supply)
- Ⓖ System cable for feedback, servo control
- ⊕ Integrated shield connection (functional earth) with shield clamp (scope of supply)
- Ⓗ Shielded cables of the motor, motor holding brake and brake resistor connections  
 Motor cable, shielded, low-capacitance (see also technical data, page 30)  
 $\leq 2.5 \text{ mm}^2$  (AWG 14): Core/core  $\leq 75 \text{ pF/m}$ ; core/shield  $\leq 150 \text{ pF/m}$   
 $\geq 4.0 \text{ mm}^2$  (AWG 12): Core/core  $\leq 150 \text{ pF/m}$ ; core/shield  $\leq 300 \text{ pF/m}$
- ⊕ Integrated PE conductor connection

### 6.3.2 Mains connection, DC supply

- ▶ Power supply modules, mains chokes or mains filters may be connected to the mains via unshielded single cores or unshielded cables.
- ▶ Cables between mains filters/RFI filters and power supply modules:
  - Install twisted and with sufficient distance to adjacent cables.
  - If cables are routed together in a cable duct or if longer cable lengths are used, we recommend the use of shielded cables, e.g. between two control cabinets.
- ▶ The integrated DC busbars (X101/102) do not require EMC measures.
- ▶ Installation of cables for DC supply:
  - Up to a length of 300 mm, twisted unshielded cables can be used, e.g. between an upper and a lower installation row.
  - From a length of 300 mm onwards, we recommend the use of shielded cables, e.g. between two control cabinets.
- ▶ The cable cross-section must be dimensioned for the assigned fusing (observe national and regional regulations).

## 6.3.3 Motor cable

- ▶ Only use shielded motor cables with braids made of tinned or nickel-plated copper. Shields made of steel braids are not suitable.
  - The overlap rate of the braid must be at least 70 % with an overlap angle of 90 °.
- ▶ The cables used must correspond to the requirements at the location (e.g. EN 60204-1).
- ▶ Connect the shield with a large surface and fix it with metal cable binders or a conductive clamp.
- ▶ Connect the shield directly to the corresponding device shield sheet.
  - If required, additionally connect the shield to the conductive and earthed mounting plate in the control cabinet.
- ▶ The motor cable is optimally installed if
  - it is separated from mains cables and control cables,
  - it only crosses mains cables and control cables at right angles,
  - it is not interrupted.
- ▶ If the motor cable must be opened all the same (e.g. due to chokes, contactors, or terminals):
  - The unshielded cable ends may not be longer than 100 mm (depending on the cable cross-section).
  - Install chokes, contactors, terminals etc. spatially separated from other components (with a min. distance of 100 mm).
  - Install the shield of the motor cable directly before and behind the point of separation to the mounting plate with a large surface.
- ▶ Connect the shield with a large surface to PE in the terminal box of the motor at the motor housing.
  - Metal EMC cable glands at the motor terminal box ensure a large surface connection of the shield with the motor housing.

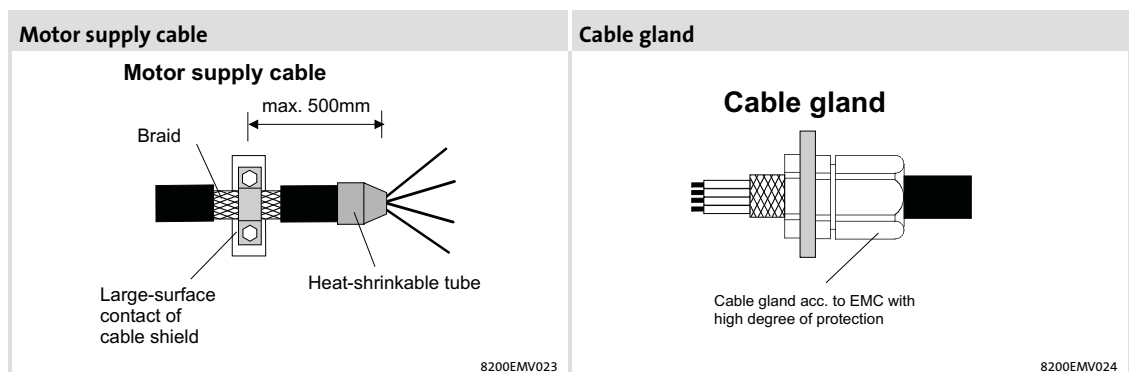

Fig. 6-2 Shielding of the motor cable



### 6.3.4 Installation in the control cabinet

#### Mounting plate requirements

- ▶ Only use mounting plates with conductive surfaces (zinc-coated or V2A-steel).
- ▶ Painted mounting plates are not suitable even if the paint is removed from the contact surfaces.
- ▶ If several mounting plates are used, ensure a large-surface connection between the mounting plates (e.g. by using earthing strips).

#### Mounting of the components

The trouble-free operation of power supply modules with an external brake resistor is only ensured if an axis module is installed in the immediate vicinity. Preferably by end-to-end mounting and use of the DC busbar system (X101/X102).

- ▶ Connect the controller and RFI filter to the grounded mounting plate with a surface as large as possible.
- ▶ No DIN rail mounting!

#### Optimum cable routing

- ▶ The motor cable is optimally installed if
  - it is separated from mains cables and control cables,
  - it crosses mains cables and control cables at right angles.
- ▶ Always install cables close to the mounting plate (reference potential), as freely suspended cables act like aerials.
- ▶ Lead the cables to the terminals in a straight line (avoid tangles of cables).
- ▶ Use separated cable channels for motor cables and control cables. Do not mix up different cable types in one cable channel.
- ▶ Minimise coupling capacities and coupling inductances by avoiding unnecessary cable lengths and reserve loops.
- ▶ Short-circuit unused cores to the reference potential.
- ▶ Install the positive and negative wires for DC 24 V close to each other over the entire length to avoid loops.

#### Earth connections

- ▶ Connect all components (drive controllers, chokes, filters) to a central earthing point (PE rail).
- ▶ Set up a star-shape earthing system.
- ▶ Comply with the corresponding minimum cable cross-sections.

**Continuation of cable routing**

Separation of the "hot" motor cable from the control, signal, and mains cables:

- ▶ Never install motor and signal cables in parallel and only cross at right angles
- ▶ The cables of a 24 V power supply unit (plus and minus cable) must be installed closely together over their entire length in order that no loops may occur.

### 6.3.5 Wiring outside of the control cabinet

Notes for cable routing outside the control cabinet:

- ▶ The longer the cables the greater the space between the cables must be.
- ▶ If cables for different signal types are routed in parallel, the interferences can be minimized by means of a metal barrier or separated cable ducts.

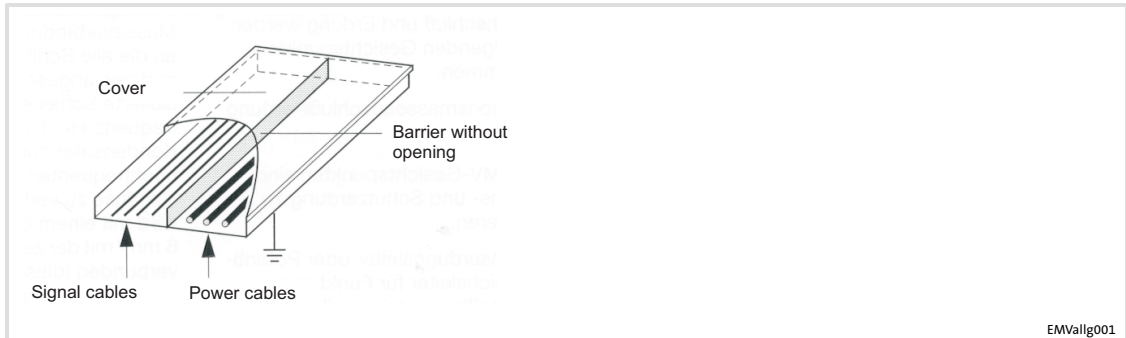

Fig. 6-3 Cable routing in the cable duct with barrier

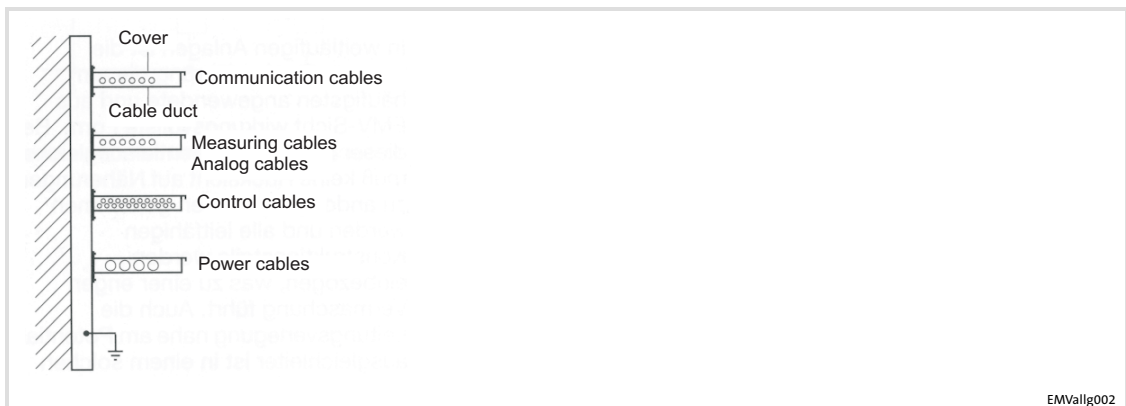

Fig. 6-4 Cable routing in separated cable ducts

### Wiring on the motor side



#### Note!

The motor cable is highly susceptible to interference. Therefore you will achieve an optimum wiring on the motor side if you

- ▶ exclusively use shielded and low-capacitance motor cables.
- ▶ do **not** integrate any further cable into the motor cable (e.g. for blowers etc.).
- ▶ shield the supply cable for temperature monitoring of the motor (PTC or thermostat) and install it separately from the motor cable.

**6.3.6 Detecting and eliminating EMC interferences**

<b>Fault</b>	<b>Cause</b>	<b>Remedy</b>
Interferences of analog setpoints of your own or other devices and measuring systems	Unshielded motor cable	Use shielded motor cable
	Shield contact is not extensive enough	Carry out optimal shielding as specified
	Shield of the motor cable is interrupted by terminal strips, switched, etc.	<ul style="list-style-type: none"> <li>● Separate components from other component part with a minimum distance of 100 mm</li> <li>● Use motor choke/motor filter</li> </ul>
	Install additional unshielded cables inside the motor cable (e.g. for motor temperature monitoring)	Install and shield additional cables separately
	Too long and unshielded cable ends of the motor cable	Shorten unshielded cable ends to maximally 40 mm
Conducted interference level is exceeded on the supply side	Terminal strips for the motor cable are directly located next to the mains terminals	Spatially separate the terminal strips for the motor cable from main terminals and other control terminals with a minimum distance of 100 mm
	Mounting plate varnished	Optimise PE connection: <ul style="list-style-type: none"> <li>● Remove varnish</li> <li>● Use zinc-coated mounting plate</li> </ul>
	HF short circuit	Check cable routing

## 6.4 Measures when drive is used in IT systems

Device-internal EMC filters have been implemented to reduce interference emission. These EMC filters are connected to protective earth to discharge interference currents.

For the use in the IT system, the device-internal capacitors must be separated from PE, in order to protect the devices against damage or destruction by incompatible overvoltages in the event of an error (earth fault).

- The separation is carried out on the power supply modules by the removal of screws.

### Overview of the measures

The measures can be carried out easily. They are prepared device-dependently, and their mounting and wiring are described.

Device	Measure for operation in the IT system
Controllers	
E70ACM...	No measure
Power supply modules	
E70ACPSx0304x	Remove two screws (Fig. 6-5)
E70ACPSx0604x	Remove one screw (Fig. 6-5)
Regenerative power supply modules	
E94ARNE0xx4	According to the mounting instructions
Suitable mains filter	According to the mounting instructions

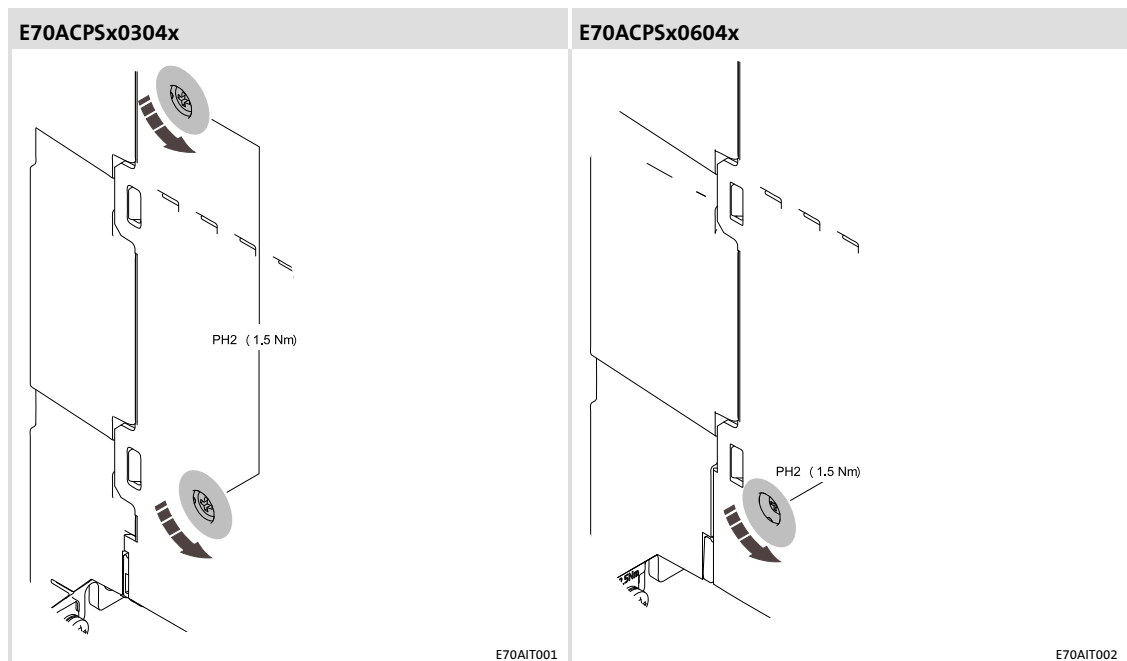

Fig. 6-5 Position of the screws to be removed



### Stop!

#### Only operate the controllers with the mains chokes assigned.

Operation with mains filters or RFI filters by Lenze is not permitted, as these modules contain components that are interconnected against PE. By this the protective design of the IT system would be cancelled out. The components are destroyed in the case of an earth fault.

#### Protect the IT system against earth fault at the controller.

Due to physical conditions, an earth fault on the motor side at the controller can interfere with or damage other devices on the same IT system. Therefore appropriate measures have to be implemented, by means of which the earth fault is detected and which disconnect the controller from the mains.

### Permissible supply forms and electrical supply conditions

Mains	Operation of the controllers	Comments
With an isolated neutral point (IT systems)	Permissible if an earth fault is detected and eliminated by suitable mechanisms as soon as possible.	<ul style="list-style-type: none"> <li>• An earth fault on the motor side with a switching frequency of 4 kHz or 8 kHz can cause a safety shutdown of the device.</li> <li>• An earth fault on the motor side at 16 kHz presents an impermissible load for the controller.</li> </ul>

### Permissible supply forms and electrical supply conditions

Mains	Operation of the controllers	Notes
With isolated star point (IT systems)	Possible, if the controller is protected in the event of an earth fault in the supplying mains. <ul style="list-style-type: none"> <li>• Possible, if appropriate earth fault detections are available and</li> <li>• the controller is immediately disconnected from the mains.</li> </ul>	Safe operation in the event of an earth fault at the inverter output cannot be guaranteed.

### Installation of the CE-typical drive system

For the installation of drives on IT systems, the same conditions apply as for the installation on systems with an earthed neutral point.

According to the binding EMC product standard EN61800-3, no limit values are defined for IT systems for noise emission in the high-frequency range.

## 6.5 Preparations

When the mechanical installation has been completed, the electrical wiring starts with the creation of the integrated electrical connections:

### 6.5.1 Integrated PE conductor connection

How to proceed:

- ▶ Use the swivel hook to establish the PE conductor connection of the devices.
  - Loosen the screws
  - Turn the swivel hook into the right position
  - Fasten the screws
- ▶ At the left and right device of an installation row, attach the PE connection twice conforming to standards.
- ▶ Then attach the shield connection sheet.

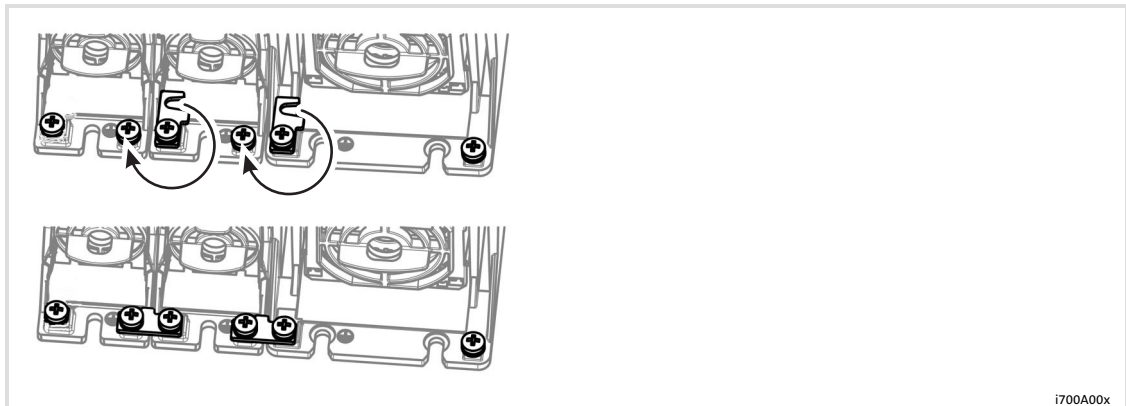

#### Terminal data

	Conductor cross-section		Tightening torque		
	[mm <sup>2</sup> ]	[AWG]	[Nm]	[lb-in]	
Swivel hook ⊕	-	-	2.5	22.1	PH 2

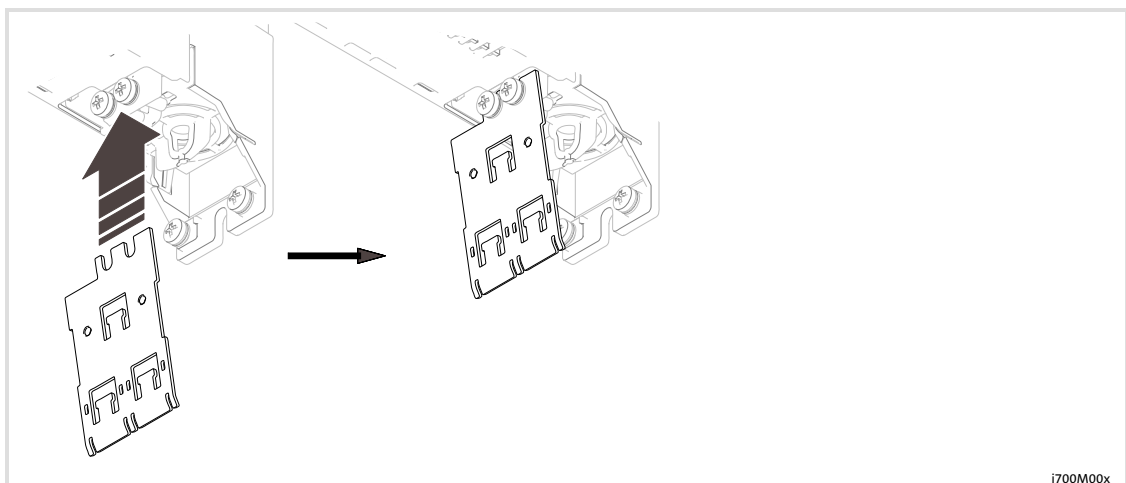

## 6.5.2 Integrated DC bus connection

- Establish the DC bus connection from the power supply module up to the last axis module

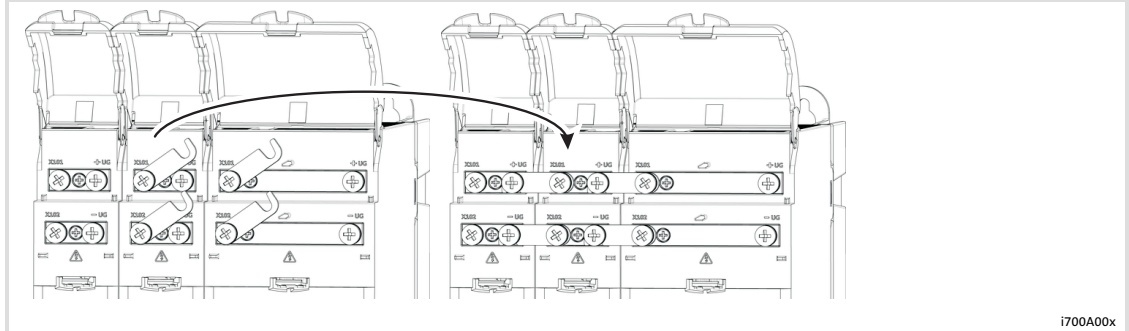

## Terminal data

	Conductor cross-section		Tightening torque		 PH 3
	[mm <sup>2</sup> ]	[AWG]	[Nm]	[lb-in]	
Swivel hook	-	-	5.0	44.3	PH 3











## 6.6 Power supply modules

For all connections, the chapter "Technical data, connection description" provides the following detailed information:

- ▶ Rated data
- ▶ Assignment
- ▶ Circuit diagram for the electrical connection

Interconnections required for the power supply module:

Connections and elements		Info
X20.1	Digital inputs	
X20.2	Digital outputs	 47
X21	External 24-V supply	 46
X100	Mains connection	 48
X101	DC-bus voltage +UG	
X102	DC-bus voltage -UG	 49
X103	Connection of brake resistor	 50
	PE conductor	 103
	Shield connection (functional earth)	 103

The basic circuit diagram provides a complete overview of the wiring of the devices.

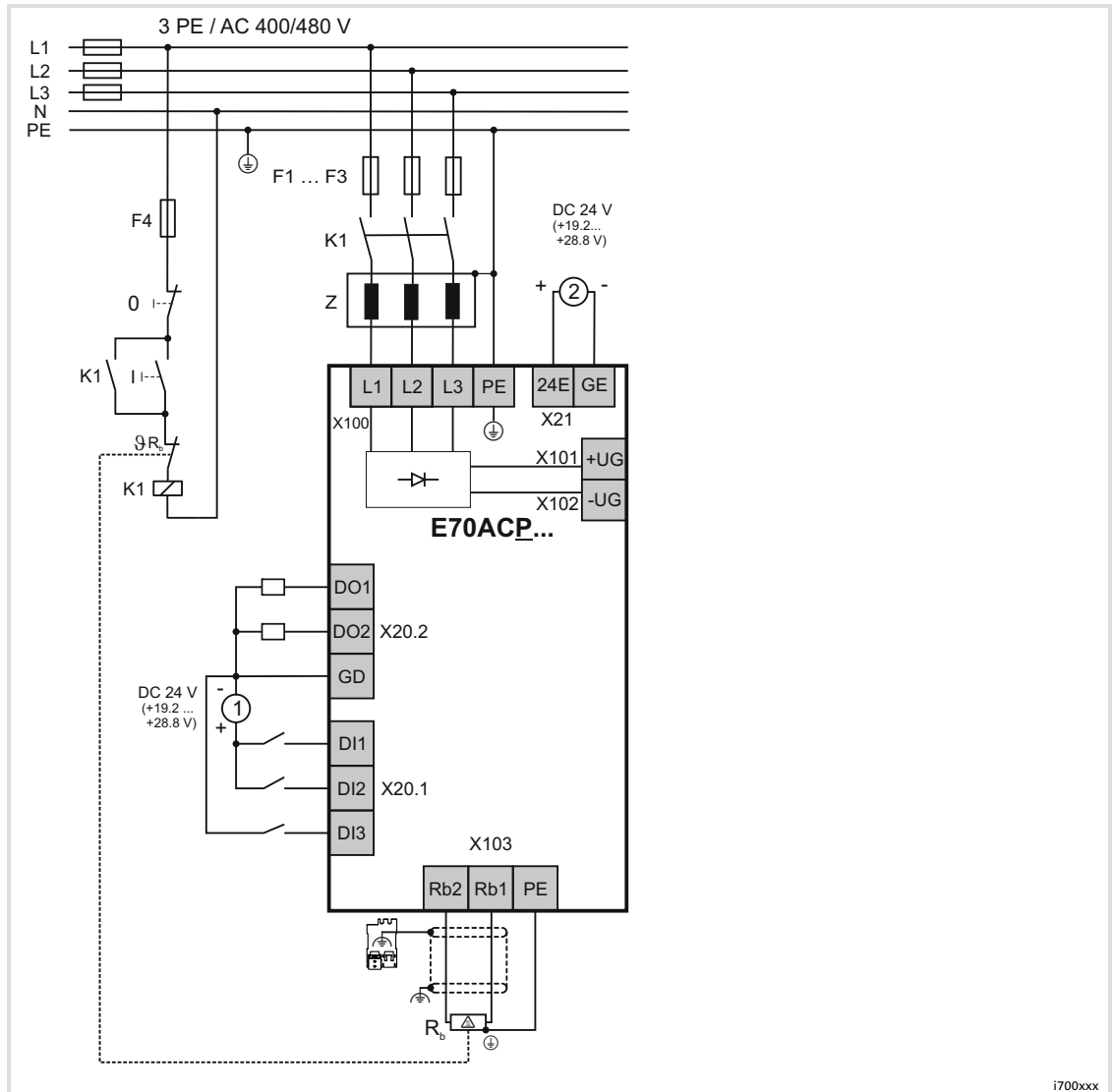

Fig. 10 Basic circuit diagram - power supply modules















E70ACP...	i700 power supply module
F...	Fuses
K	Mains contactor with latch circuit
Z	Filter
R <sub>b</sub>	External brake resistor
①	24-V supply of digital inputs and outputs
②	24-V supply of control electronics

## 6.7 Axis modules

For all connections, the chapter "Technical data, connection description" provides the following detailed information:

- ▶ Rated data
- ▶ Assignment
- ▶ Circuit diagram for the electrical connection

Interconnections required for the axis module:

Connections and elements		Info
X1	Basic Safety - STO	 52  135
X2	Touch probe	 53
X3	External 24-V supply	 54
X4	EtherCAT IN	
X5	EtherCAT OUT	 55
Servo control feedback (alternative)		
	X7 - resolver	 57
	X8 - encoder	 59
X101	DC-bus voltage +UG	
X102	DC-bus voltage -UG	 61
X108	Motor A	
X107	Motor B	 64
X105	24-V supply of motor holding brake(s)	 62
X106	Motor holding brake	 63
	PE conductor	 103
	Shield connection (functional earth)	 103



### Note!

If integrated safety is not to be used for an axis, the safe inputs SIA and SIB of the axis must be fixedly assigned with "HIGH" potential (24 V).

The wiring should not give the impression of connected safety sensors, or should be provided with adequate labelling.

The basic circuit diagram provides a complete overview of the wiring of the devices.

### Single axis module

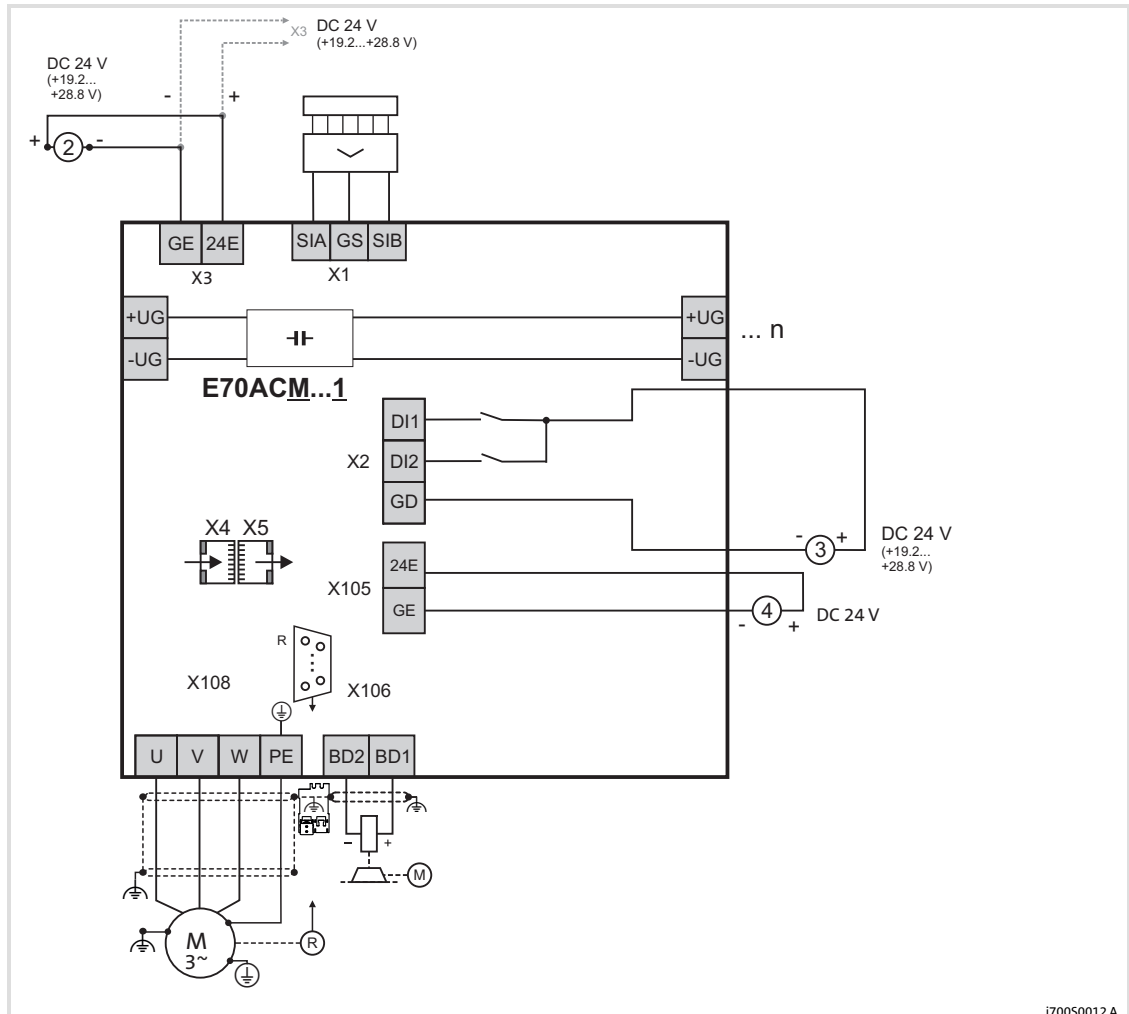

Fig. 11 Basic circuit diagram - axis modules

E70ACM...1	i700 "single inverter" single axis module - motor A
...n	Other i700 axis modules
②	24-V supply of control electronics
③	24-V supply of digital inputs
④	24-V supply of motor holding brake(s)
R	Servo control feedback (X7 = resolver or X8 = encoder)

Double axis module

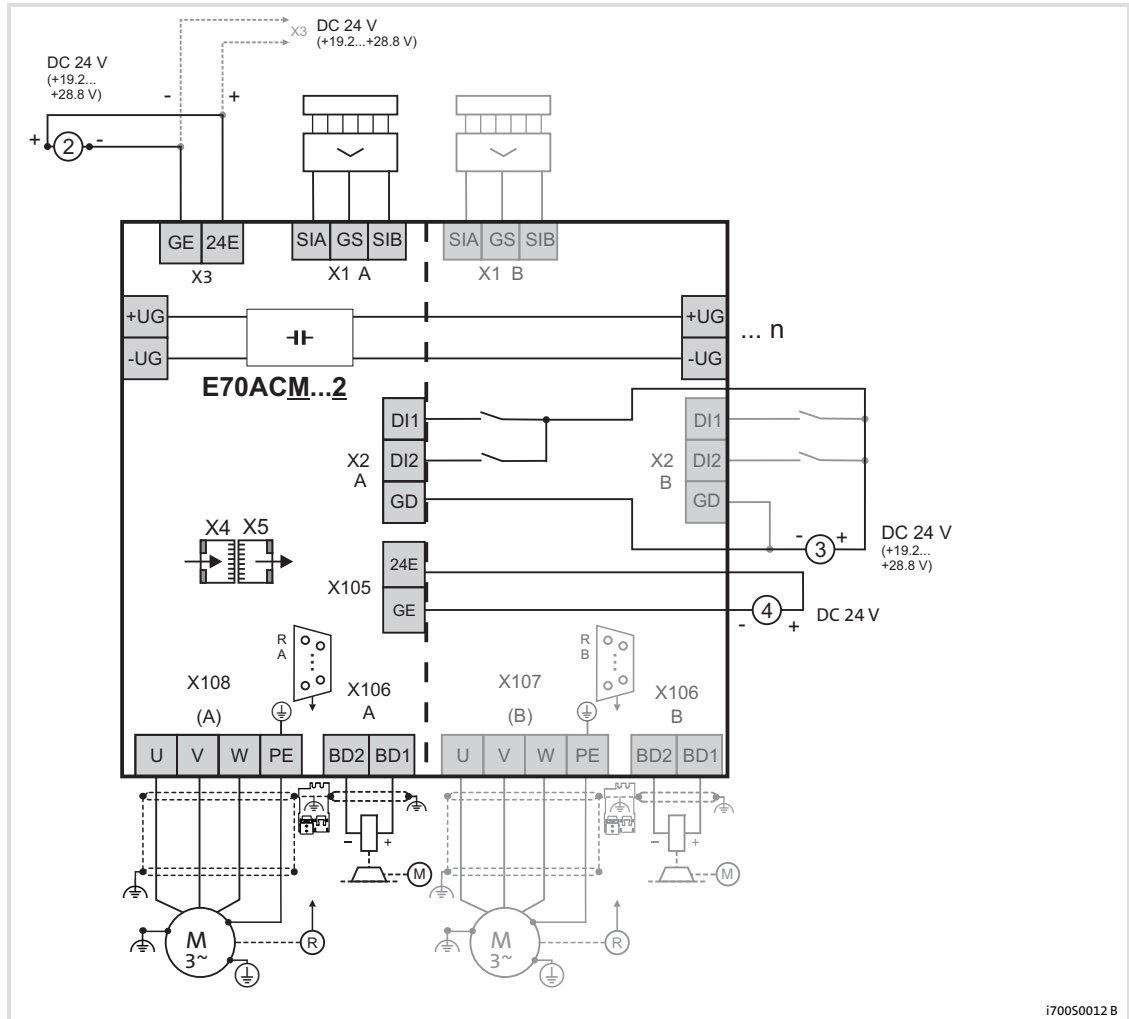

Fig. 12 Basic circuit diagram - axis modules

- |            |   |
|------------|---|
| E70ACM...2 | i700 double axis module "double inverter" - motor A and motor B |
| ...n       | Other i700 axis modules   |
| ②          | 24-V supply of control electronics                              |
| ③          | 24-V supply of digital inputs                                   |
| ④          | 24-V supply of motor holding brake(s)                           |
| R          | Servo control feedback (X7 = resolver or X8 = encoder)          |

## **7 DC-bus operation**

Introduction  
Terminology and abbreviations used

## **7 DC-bus operation**

### **7.1 Introduction**

#### **7.1.1 Terminology and abbreviations used**

Explanations of special terms concerning DC-bus operation can be found in the chapter "About this documentation" under "Terminology and abbreviations used" (📖 10).

#### **7.1.2 Advantages of a drive system**

When several controllers are operated in a DC-bus connection (DC bus), this offers the following advantages:

- ▶ Energy exchange between controllers in generator-mode (braking) and motor-mode operation.
- ▶ The energy exchange reduces the supply power from the AC mains.
- ▶ DC-supply modules or feeding single-axis controllers can be dimensioned with a lower rated power.
- ▶ The energy exchange reduces the braking losses in generator-mode operation.

Advantages for installation:

- ▶ Only one AC-mains connection (e.g. at the DC-supply module).
- ▶ Reduced wiring costs.

## 7.2 Conditions for trouble-free DC-bus operation

### 7.2.1 Voltages

The DC-bus operation of controllers is only possible if the rated values of the mains voltage or DC-bus voltage are identical. The switching thresholds of all brake choppers in the interconnected system have to be set identically and the control has to be synchronised by master/slave interconnection.

### 7.2.2 Number of feeding points

The "i700 servo inverter" series has been designed for drive systems with a central AC mains feeding point. For this you can use DC supply modules of different power categories.

It is permissible to operate DC power supply modules in parallel in order to increase the supply or braking power. Using the assigned mains chokes ensures a distribution of the mains input current in accordance with the rated data.

The spacial arrangement of the DC power supply modules in the network can be selected freely according to the requirements.

Examples:

- ▶ Arrangement of DC power supply modules to the left and right of the axis interconnection for power increase  $P_{DC}$  and optimised current distribution in the busbar system
- ▶ Arrangement of DC power supply modules directly next to the axes with dominant punctual motor power or regenerative power.



#### Tip!

Your Lenze contact person will advise you on further possible supply concepts.

### 7.2.3 Other conditions

- ▶ The entire DC power  $P_{DC}$  must be provided by the feeding point.
- ▶ The controllers of the interconnected system may only start operation when the DC bus has been charged completely.
- ▶ Up to a total current of 120 A, the controllers can be operated via the integrated DC-bus connections.
  - Maximum overload of the busbar for 60 s:  $150 \% * I_r$  with a subsequent 120 s recovery phase:  $75 \% * I_r$ .
- ▶ The DC bus must at no time be overloaded through the required maximum total power. For this, a time/performance diagram has to be created and considered (see Basic dimensioning).

# 7

## DC-bus operation

DC-bus variants

Supply with one power supply module

### 7.3

#### DC-bus variants

#### 7.3.1

#### Supply with one power supply module

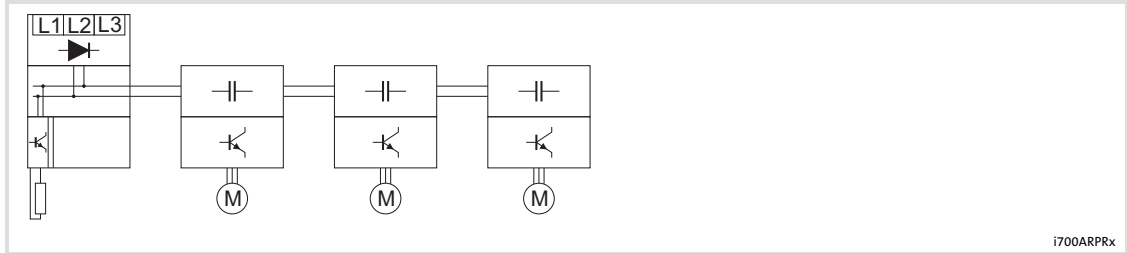

A DC supply module with direct AC mains connection supplies energy into the DC bus of several controllers. The DC supply module is equipped with an integrated brake chopper to which you can connect a brake resistor.

Components to be used	
i700 device series	Other device series
<b>DC supply</b>	
Power supply modules	
E70ACPSx0304x (30 A)	-
E70ACPSx0604x (60 A)	-
<b>Filter</b>	
RFI filters	
-	E94AZRP0084 E94AZRP0294 E94AZRP0824
Mains filters	
-	E94AZMP0084 E94AZMP0294 E94AZMP0824
<b>Interconnected device</b>	
Controllers	
E70ACM...1... (single axis)	-
E70ACM...2... (double axis)	-



7.3.2 Supply with power supply modules operated in parallel

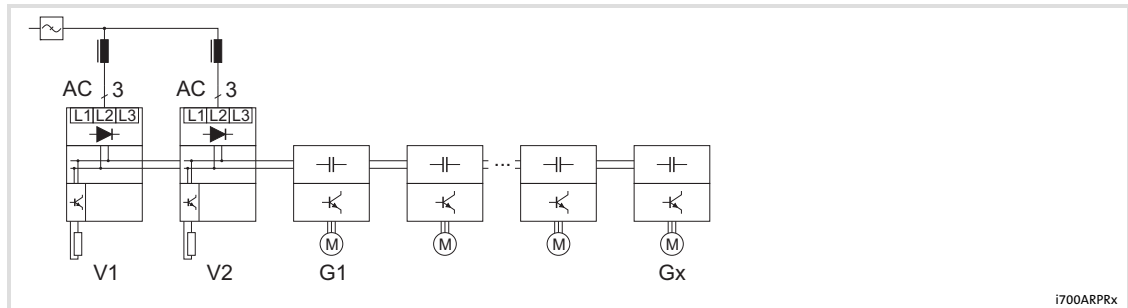

AC  
V1, V2  
G1 ... Gx

AC mains  
Power supply modules  
Controllers

Power supply modules can be operated in parallel in order to increase the DC supply power and/or the braking power.

For the central connection of power supply modules operated in parallel to the AC mains, the filters must be dimensioned as collective filters.

Components to be used	
i700 device series	Other device series
<b>DC supply</b>	
Power supply modules	
E70ACPSx0304x (30 A)	-
E70ACPSx0604x (60 A)	-
<b>Mains chokes</b>	
-	EZAELN3025B122 EZAELN3050B591
<b>Filter</b>	
RFI filters	
-	-
Mains filters	
-	E94AZMP0084 E94AZMP0294 E94AZMP0824
<b>Interconnected device</b>	
Controllers	
E70ACM...1... (single axis)	-
E70ACM...2... (double axis)	-

## 7.3.3

## Supply with regenerative power supply module

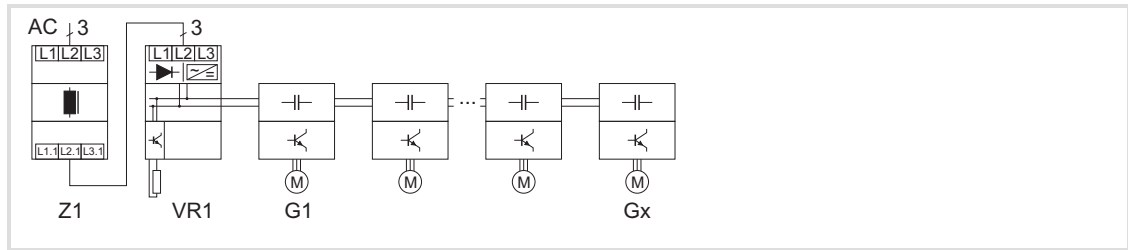

AC	AC mains
Z1	Regenerative power supply filter
VR1	Regenerative power supply module
G1 ... Gx	Controllers

If the regenerative energy produced by a drive system is to be fed back to the AC mains, a regenerative power supply module of the "Servo Drives 9400" device series can be used. A brake chopper, to which a brake resistor can be connected, is integrated.

## Components to be used

## i700 device series

## Other device series

## DC supply

Regenerative power supply modules

-

E94ARNE0xx4 + E94AZMR0xx4xDB (13 ... 24 A)

## Filter

- assigned to the regenerative power supply module

## Interconnected device

Controllers

E70ACM...1... (single axis)

-

E70ACM...2... (double axis)

-

## 7.4 Rated data

### 7.4.1 General data

The total current of the nominal input currents  $I_{DC}$  to be provided by the power supply module must be determined. If required, the DC cables must be dimensioned in accordance with the total current.

Additional data	Input current $I_{DC}$ at $I_{ar}$ [A]	DC-bus capacity [ $\mu$ F]	Charging resistor [ $\Omega$ ]
E70ACMxx0054xx1xxx	5.0	165	100
E70ACMxx0104xx1xxx	9.3	165	100
E70ACMxx0204xx1xxx	18.4	330	100
E70ACMxx0324xx1xxx	29.8	720	34
E70ACMxx0484xx1xxx	44.6	1080	34
E70ACMxx0644xx1xxx	59.5	1080	34
E70ACMxx0054xx2xxx	9.3	165	100
E70ACMxx0104xx2xxx	18.4	330	100
E70ACMxx0204xx2xxx	37.3	720	34
E70ACMxx0324xx2xxx	59.5	1080	34

Tab. 7-1  
 DCbus = DC bus

### 7.4.2 DC-supply power

The parameters relevant for the selection of a supply unit with a suitable supply power (even in the overload range) are listed in the below table:

$U_{LN}$	Rated AC voltage
Cycle 1	Cycle for the second-range
Cycle 2	Cycle for the minute-range
$P_{DC\ 100\%}$	Permanent power of DC-voltage level
$P_{ol}$	Power supply during overload time
$t_{ol}$	Overload time
$P_{re}$	Power supply during unloading time
$t_{re}$	Relief time

Any other cycles are calculated with the following formula:

$$\frac{(P_{ol} \cdot t_{ol}) + (P_{re} \cdot t_{re})}{t_{ol} + t_{re}} \leq P_{DC\ 100\%}$$

Cycles other than the above cycles must not exceed the specified power and time values, i.e. the values must be used as maximum values.

The values depend on the rated AC voltage  $U_{Lr}$ .

## 400 V

Power supply $U_{Lr} = 400\text{ V}$		Cycle 1		Cycle 2	
Type	$P_{DC\ 100\%}$ [kW]	$P_{ol} \cdot t_{ol}$ [kW] · [s]	$P_{re} \cdot t_{re}$ [kW] · [s]	$P_{ol} \cdot t_{ol}$ [kW] · [s]	$P_{re} \cdot t_{re}$ [kW] · [s]
<b>Supply modules (+ filter)</b>					
E70ACPSx0304x	10.3	20.6 · 3	6.8 · 12	15.5 · 60	7.7 · 120
E70ACPSx0304x + E94AZMP0084					
E70ACPSx0304x + E94AZMP0294	15.4	30.8 · 3	10.2 · 12	23.1 · 60	11.6 · 120
E70ACPSx0604x	20.6	41.2 · 3	13.6 · 12	30.9 · 60	15.5 · 120
E70ACPSx0604x + E94AZMP0824	30.9	61.8 · 3	20.4 · 12	46.4 · 60	23.2 · 120
<b>Regenerative power supply modules + filters</b>					
E94ARNE0134 + E94AZMR0264xDB	15.0	44.9 · 3	11.3 · 12	22.4 · 60	11.3 · 120
E94ARNE0244 + E94AZMR0474xDB	27.0	81.1 · 3	20.3 · 12	43 · 60	20.3 · 120

Tab. 7-2

## 480 V

Power supply $U_{Lr} = 480\text{ V}$		Cycle 1		Cycle 2	
Type	$P_{DC\ 100\%}$ [kW]	$P_{ol} \cdot t_{ol}$ [kW] · [s]	$P_{re} \cdot t_{re}$ [kW] · [s]	$P_{ol} \cdot t_{ol}$ [kW] · [s]	$P_{re} \cdot t_{re}$ [kW] · [s]
<b>Supply modules (+ filter)</b>					
E70ACPSx0304x	12.3	24.6 · 3	8.1 · 12	18.5 · 60	9.2 · 120
E70ACPSx0304x + E94AZMP0084					
E70ACPSx0304x + E94AZMP0294	18.5	37.0 · 3	12.2 · 12	27.8 · 60	13.9 · 120
E70ACPSx0604x	24.7	49.4 · 3	16.3 · 12	37.1 · 60	18.5 · 120
E70ACPSx0604S + E94AZMP0824	37.0	74.0 · 3	24.4 · 12	55.5 · 60	27.8 · 120
<b>Regenerative power supply modules + filters</b>					
E94ARNE0134 + E94AZMR0264xDB	18.6	56.1 · 3	14.0 · 12	28.0 · 60	14.0 · 120
E94ARNE0244 + E94AZMR0474xDB	33.8	101.4 · 3	25.4 · 12	50.7 · 60	25.4 · 120

Tab. 7-3

### 7.4.3 DC-power requirements

Use the below tables to determine the power requirements of the devices used in the DC bus and the device-dependent power loss for the rated mains voltage  $U_{Lr}$ .

Power requirements $P_{ar}$ [W] with rated current		
	$U_{Lr} = 400\text{ V}$	$U_{Lr} = 480\text{ V}$
E70ACMxx0054xx1xxx	1700	2000
E70ACMxx0104xx1xxx	3200	3800
E70ACMxx0204xx1xxx	6300	6100
E70ACMxx0324xx1xxx	10200	9800
E70ACMxx0484xx1xxx	15300	14700
E70ACMxx0644xx1xxx	20400	19600
E70ACMxx0054xx2xxx	3200	3800
E70ACMxx0104xx2xxx	6300	7700
E70ACMxx0204xx2xxx	12800	12300
E70ACMxx0324xx2xxx	20400	19600

Tab. 7-4

Consider the following criteria when using mains chokes:

- ▶ Mains chokes are always required if all interconnected devices are operated with rated current and speed.
- ▶ Mains chokes are not required if the power of the entire network is less than 50 % of the added continuous powers of all interconnected devices (= standard case).

$$\Sigma P_a \leq 0.5 \cdot \Sigma P_{ar}$$

$\Sigma P_a$

Sum of the average output power of the axes in the network  
Medium mains power, depending on the "in motor mode/in generator mode" operating status, motor current, motor speed and device losses

$\Sigma P_{ar}$

Sum of the rated power of the axes in the network

- ▶ The use of mains chokes for complying with the EMC category C3 has to be assessed separately (☞ 122).

	Power loss $P_V$ [W]		
	$U_{Lr} = 400\text{ V}$	$U_{Lr} = 480\text{ V}$	when controller is inhibited
E70ACMxx0054xx1xxx	50	50	20
E70ACMxx0104xx1xxx	80	80	20
E70ACMxx0204xx1xxx	130	130	20
E70ACMxx0324xx1xxx	210	210	35
E70ACMxx0484xx1xxx	290	300	35
E70ACMxx0644xx1xxx	390	390	45
E70ACMxx0054xx2xxx	90	90	30
E70ACMxx0104xx2xxx	140	150	30
E70ACMxx0204xx2xxx	260	260	45
E70ACMxx0324xx2xxx	370	380	45

# 7 DC-bus operation

Basic dimensioning  
General information

## 7.5 Basic dimensioning

### 7.5.1 General information

The Drive Solution Designer (DSD) PC software helps you to dimension your drive network. For expert advice, you may also contact your Lenze sales representative when dimensioning your application.

#### Time/performance diagram

For determining the performance of your drive network, create a time/performance diagram for all axes for a complete machine cycle. The power requirements of the drive network are calculated by adding the individual performances occurring at the same time. Positive results show the AC requirements for the dimensioning of the power supply units. Negative results show the brake power to be dissipated via brake choppers at the brake resistor.

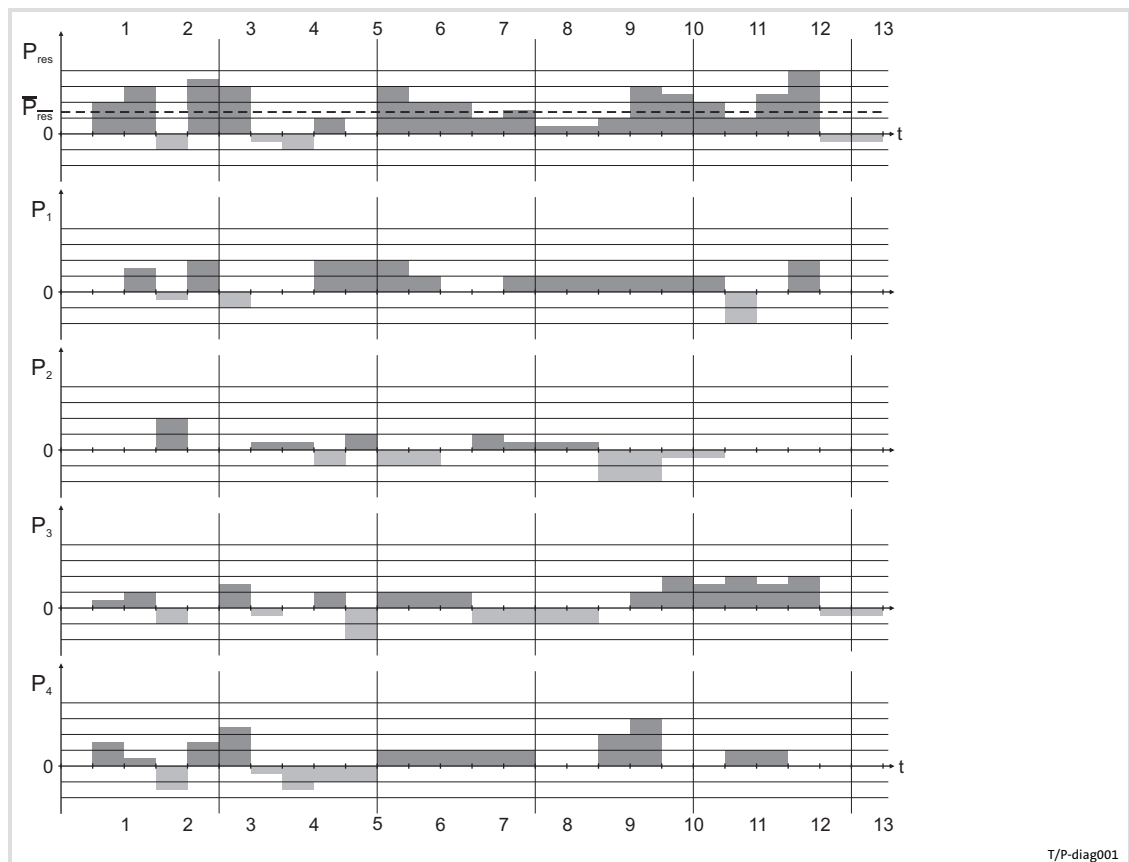

Fig. 7-1 Example time/performance diagram

$P_1 \dots P_4$	Individual performances of axes 1 ... 4
$P_{total}$	Addition of the individual performances
$\overline{P}_{total}$	Average of the individual performances

Use the time/performance diagram to optimise the DC-bus performance of all axes for a complete machine cycle.

### Utilisation factor

Please consider the utilisation factors when determining  $P_{DCtotal}$ . Reduce the power requirements if the rated power is not fully used.

### Simultaneity factor

Please consider the simultaneity factor when determining  $P_{DCtotal}$ . Reduce the power requirements if the drives do not run simultaneously or in opposite direction (braking).

### Braking operation

After determining the brake power  $P_{BRtotal}$ , ensure that the brake power can be provided by the brake choppers and brake resistors in the DC bus.

### Other conditions

The power supply unit must be able to provide the required power (arithmetic mean).

The overload requirements must be within the permissible range:

( 7.4.2)

- ▶ 3-min cycle (1 min overload with 150 % and 2 min recovery time with 75 %)
- ▶ 15-s cycle (3 s overload with 200 % and 12 s recovery time with 75 %)

For detailed information on the overload capacity, please see the Technical data.

## 7.5.2 Power distribution of controllers

In a DC-bus operation, the power from the AC mains is stored in the DC bus and consumed by several controllers. Drive groups with non-synchronous power consumption, partial load or excess energy from braking operations are suitable for establishing a DC-bus connection.

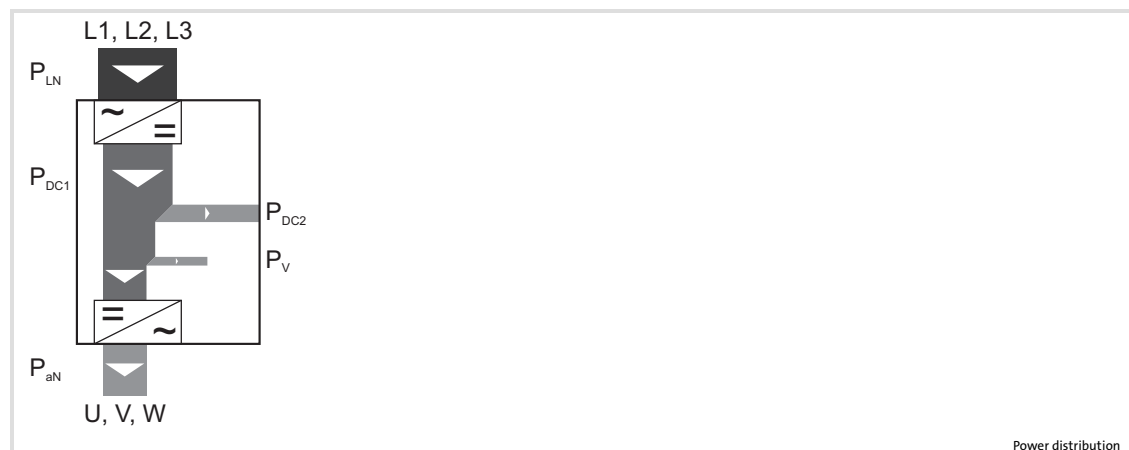

L1, L2, L3	Mains connection (3/PE AC)
$P_{LN}$	Input mains power
$P_{DC1}$	Total DC-bus power
$P_{DC2}$	DC-bus power available for the DC bus
$P_{loss}$	Power loss
$P_{ar}$	Output power
U, V, W	Motor connection

## 7 DC-bus operation

Basic dimensioning  
Motor efficiency

### 7.5.3 Motor efficiency

For determining the power requirements, you have to consider the shaft power  $P_{\text{shaft}}$  and the motor efficiency. The motor efficiency can be found under the motor data.

### 7.5.4 Power loss of devices

When determining the power requirements, the power loss of the devices must be considered (📖 Tab. 7-4).

### 7.5.5 Determining the power requirements

For determining the power requirements of the drive system you need to know the rated power of the motors and their efficiency as well as the power losses of the controllers. The power requirements are calculated with the following formula:

$$P_{DCtotal} = \sum_{i=1}^n \left\{ \frac{(P_{\text{shaft}})_i}{\eta_i} + (P_{\text{loss}})_i \right\}$$

$P_{DCtotal}$	Total power required by the drive system
$P_{\text{shaft}}$	Rated power of a connected motor
$P_{\text{loss}}$	Power loss of a controller
$\eta$	Motor efficiency
$i$	Index variable for device identification
$n$	Number of devices in the drive system

The supplying device must be able to provide the required power that is calculated.

### 7.5.6 Determining the regenerative power requirements

With the regenerative power supply modules of the "Servo Drives 9400" series, power regeneration into the AC mains is possible. Use the determined regenerative power for the dimensioning of the regenerative power supply module.

### 7.5.7 Cable protection

In case of interferences, the cables have to be adequately protected.

Please consider the following when dimensioning the DC bus for a plant or machine:

- ▶ Mains fuses can be used to protect the DC cables if the wiring is designed for 122 % of the rated fuse current. Otherwise, the cable protection for the DC cables must be specially determined.
- ▶ Select the fuses for the currents resulting from power  $P_{DC100\%}$ . Please observe the standards and regulations applicable for the particular location and application.
- ▶ Fuse the DC-supply modules according to the Technical data on the AC mains side.
- ▶ If the DC bus is wired via the terminals +UG/-UG, always select a 2-pole cable protection.



## 7.6 Braking operation in a drive system

### 7.6.1 Basic considerations

If the regenerative power of a drive exceeds the storage capacity of the DC bus, the excessive energy must be consumed or dissipated. Target of the DC bus is to use the excessive energy for other axes.

Check for all operating situations that may occur in the DC-bus interconnection whether the brake power provided by the brake choppers is high enough for the maximum regenerative power that may occur. If necessary, several power supply modules with an integrated brake chopper can be integrated into the drive system to increase the brake power (parallel connection).

If several brake choppers are used, the following conditions must be met:

- ▶ The limiting monitoring functionalities must be considered when dimensioning the continuous brake power for the DC bus:
  - Brake chopper monitoring
  - Brake resistor monitoring
- ▶ The temperature monitoring of the brake resistors must lead to power-off, otherwise the brake resistors or devices may be destroyed.
- ▶ The brake choppers are protected by changing the duty cycle or switching them off temporarily. They are automatically switched on again.
- ▶ One device must be defined as "master", and the other devices must be defined as "slaves", in order to provide for the simultaneous switching of all brake choppers, irrespective of tolerances. How to proceed:
  - For "Slave activation", apply digital input DI3 of each slave to GND potential (GD/0 V). By this, the device-internal brake chopper switching threshold of the slave is set to a value above the tolerance zone (790 V).
  - For control by the master, interconnect digital output DO1 of the master with DI1 of the slaves. Like this, the slaves will chop on request by the master, isochronously with the master (at 765 V).

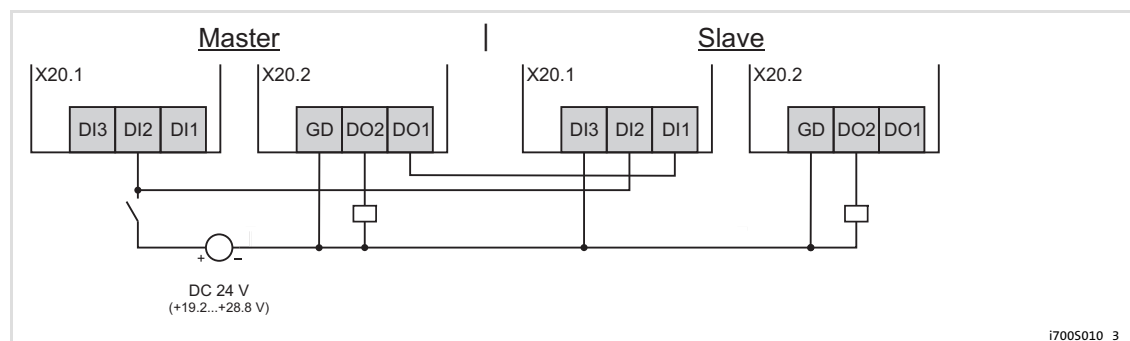

Fig. 13 Wiring of X20

X20	Connection of digital inputs and outputs at the power supply module
.1	Connector on the left-hand side
.2	Connector on the right-hand side
DIx	Digital input
DOx	Digital output (e.g. for controlling relays)
GD	Reference potential GND

## 7.7 EMC in DC-bus operation

## 7.7.1 Compliance with EMC category C3 (industrial premises)

Applications for the "second environment" on industrial premises must comply with EMC category C3.

Observe the conditions for the compliance with EMC category C3:

- ▶ The permissible motor cable length is  $\leq 50$  m for each axis.
- ▶ The maximum sum of all motor cable lengths ( $\Sigma l_{\text{mot}}$ ) must be observed.
- ▶ Without a mains choke: 4 axes x 50 m = 200 m
  - Switching frequency: 4 & 8 kHz
- ▶ With the mains chokes assigned: 10 axes x 50 m = 500 m

If the number of axes deviates,  $\Sigma l_{\text{mot}}$  can be determined from the following diagram.

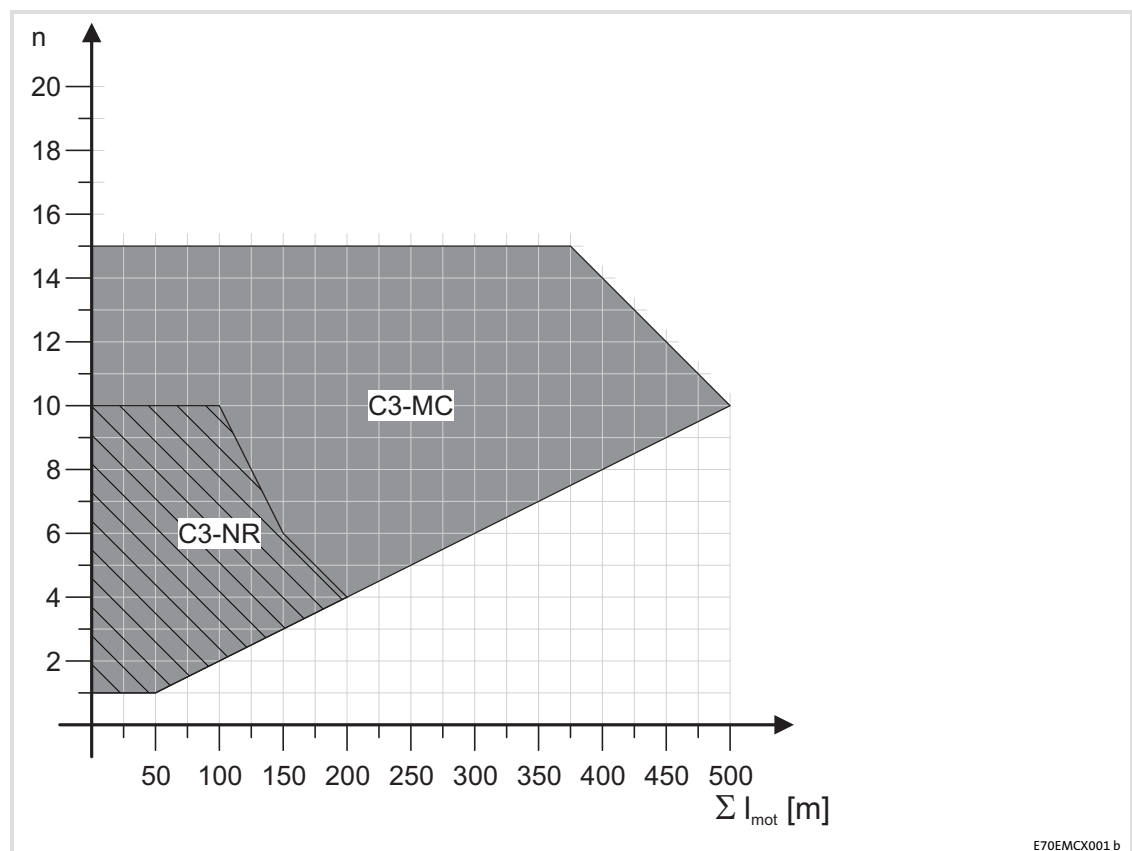

Fig. 7-2 Motor cable lengths for the compliance with category C3

n	Number of axes
$\Sigma l_{\text{mot}}$	Sum of the motor cable lengths ...
C3-NR	without mains chokes, according to the number of axes, for switching frequency 4 & 8 kHz
C3-MC	with mains chokes, according to the number of axes

### 7.7.2 Compliance with EMC category C2 (residential areas)

Applications for the "first environment" in residential areas must comply with EMC category C2.

Observe the conditions for the compliance with EMC category C2:

- ▶ The permissible motor cable length is  $\leq 50$  m for each axis.
- ▶ The maximum sum of all motor cable lengths ( $\Sigma l_{mot}$ ) must be observed.
- ▶ Filters to be used:
  - RFI filter E94AZRP...: 6 axes x 50 m = 300 m
  - Mains filter E94AZMP...: 10 axes x 50 m = 500 m

If the number of axes deviates,  $\Sigma l_{mot}$  can be determined from the following diagram.

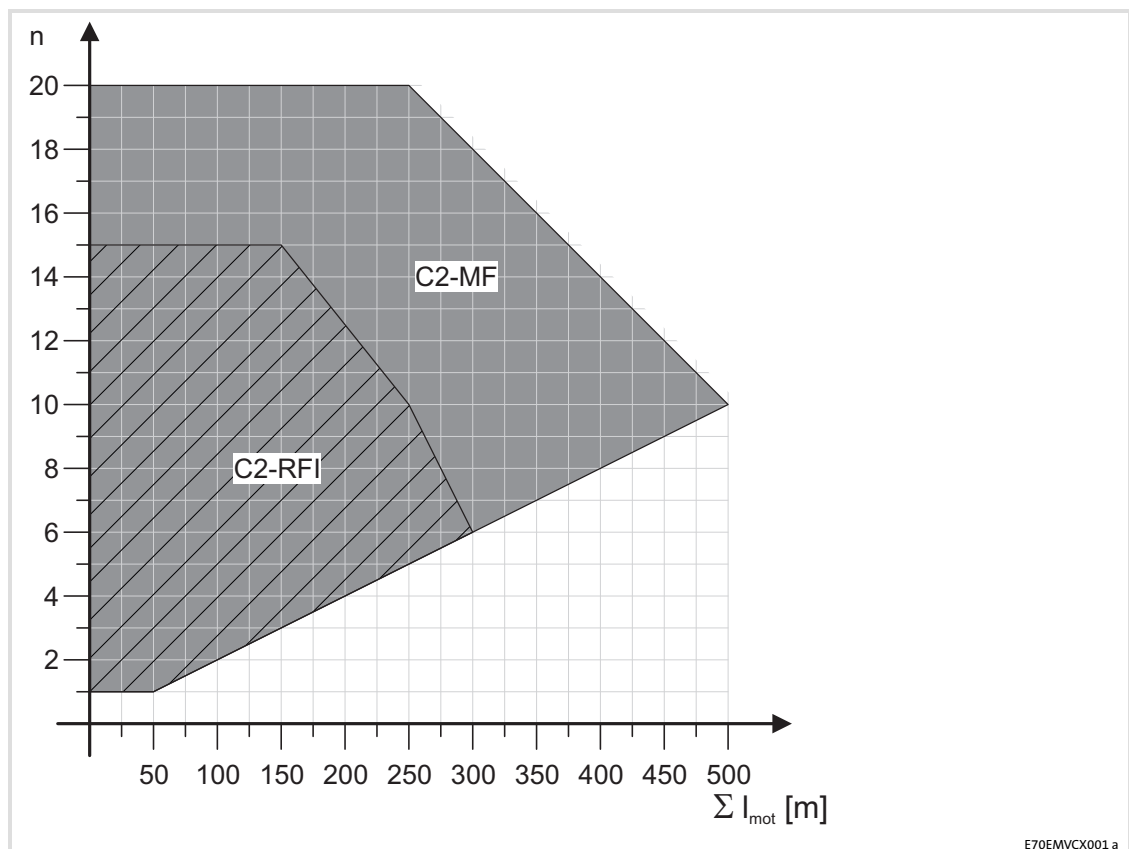

Fig. 7-3 Motor cable lengths for the compliance with category C2

n	Number of axes
$\Sigma l_{mot}$	Sum of the motor cable lengths ...
C2-RFI	for E94AZRP... RFI filters, according to the number of axes
C2-MF	for E94AZMP... mains filters, according to the number of axes

### 7.7.3 Assignment of filters

In order to comply with the EMC category C2, use filters adapted to the DC power supply modules. Install the filters E94AZ... with the outgoing cable to the top in order that this cable can be directly connected to the mains connection of the power supply module.

RFI filter	DC power supply module
E94AZRP0294	E70ACPSx0304x
E94AZRP0824	E70ACPSx0604x

The RFI filters are designed for the following conditions:

- ▶ 6 interconnected devices,
- ▶ each with a 50 m motor cable,

Mains filters	DC power supply module
E94AZMP0294	E70ACPSx0304x
E94AZMP0824	E70ACPSx0604x

The mains filters are designed for the following conditions:

- ▶ 10 interconnected devices,
- ▶ each with a 50 m motor cable,

In applications with a different number of interconnected devices or different motor cable lengths, the filters may have to be specially dimensioned.



### Note!

To observe EMC category C2, measures must be carried out on the device-internal EMC filters of the drive components in the network system. The measures for the individual devices are described in the chapter "Wiring", section "Earthing of internal EMC filters".

### Constellations with unfavourable or intensifying parasitic couplings

Compliance with EMC category C2 may also be interfered with by other circumstances:

- ▶ Distribution of the axis modules over several control cabinets without efficient HF equipotential bonding between the mounting plates
- ▶ No use of Lenze system cables or cables with the same specifications
- ▶ Poor connection of motor cable shields
- ▶ Motor cable interruptions
- ▶ Other interference sources (e.g. switched-mode power supplies)
- ▶ Isochronous switching of the inverter output stages

## 8 Commissioning



### Note!

- ▶ Please observe the general safety instructions (📖 13).
- ▶ Please observe the notes regarding residual hazards (📖 18).

### 8.1 Before switching on

**Prevent injury to persons and damage to property by checking the following before switching on the mains voltage.**

Check

- ▶ the wiring for completeness.
- ▶ for the absence of short circuits and/or earth faults.
- ▶ for the correct covering of the DC-bus wiring.
- ▶ the "EMERGENCY OFF" function of the entire system.
- ▶ the motor circuit configuration (star/delta). It must be adapted to the output voltage of the controller.
- ▶ the in-phase connection of the motor (direction of rotation).
- ▶ whether the drive mechanically can be disconnected from the machine for commissioning.



### Danger!

#### High hazard potential during commissioning

Incorrect settings can cause unexpected and dangerous movements of the motor and the equipment.

#### Possible consequences:

- ▶ Damage to material assets
- ▶ Injury to persons

#### Protective measures:

- ▶ Clear hazard area
- ▶ Observe safety instructions and safety distances

### 8.2 Quick commissioning

Quick commissioning is described in

- ▶ the "Controller-based automation, EtherCAT" communication manual,  
– the chapter "Commissioning of i700 servo inverter".

The passive power supply modules can only be diagnosed via the terminal outputs on the device.

X20			
Signal	Name	Status	Description
DO1	Brake chopper status	LOW	Brake chopper not active or 24-V supply voltage off
		HIGH	Brake chopper active
DO2	Status message	LOW	<ul style="list-style-type: none"> <li>● 24-V supply voltage is off</li> <li>● Fault: Heatsink overtemperature               <ul style="list-style-type: none"> <li>– no acknowledgement required</li> </ul> </li> <li>● Fault: Brake IGBT overcurrent/short circuit               <ul style="list-style-type: none"> <li>– acknowledgement required:</li> </ul> </li> </ul>
		HIGH	24-V supply voltage ok, module ready for operation

Acknowledgement of the status messages of the power supply modules by means of:

- ▶ Applying of 24 V (HIGH) at input DI2.
- ▶ Short-time switch-off of the 24-V supply voltage
  - If the voltage supply cannot be switched off, terminal X21 can be unplugged instead.

If the status cannot be acknowledged, the "overtemperature" or "overcurrent/short circuit" fault persists.

To diagnose the axis modules, errors and warnings are mapped in "error codes" according to the CiA 301/402 standard. Additionally, a history is available enabling a central logbook to be set up in the control system. More detailed information can be found in the software manual or in the online help.

## 9.2 LED status displays

### 9.2.1 Supply modules

LED display of power supply module - V100			
Colour	Name	Status	Description
blue	RDY	off	24-V supply voltage off or $\leq 18$ V
		is ON	24-V supply voltage ok, module ready for operation
red	ERR	off	Power supply module ready for operation
		is ON	Error/fault

### 9.2.2 Axis modules

LED display of axis module - V101			
Colour	Name	Status	Description
blue	RDY	off	24-V supply voltage off or $\leq 18$ V
		is ON	24-V supply voltage ok, module ready for operation
		blinking	Axis module inhibited
		fast blinking	Optical device identification (simultaneously with red/ERR)
red	ERR	off	Axis module ready for operation - no error - axis A (and B)
		is ON	Error/fault - device
			Error/fault - axis A (or B)
		fast blinking	Optical device identification (simultaneously with blue/RDY)

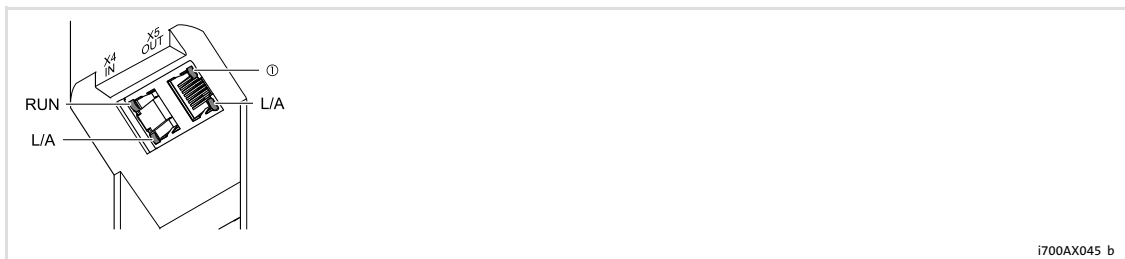

i700AX045 b

LED display of axis module - X4/X5 EtherCAT IN/OUT		
Name	Status	Description
RUN	is ON	"Operational" status is active.
	flickering	"Bootstrap" status is active.
	blinking	"Pre-operational" status is active.
	blinking once (single flash)	"Safe-operational" status is active.
	off	Fieldbus communication is not active or is in the "Init" state.
L/A	is ON	Physical EtherCAT connection is available.
	flickering	Data are exchanged via EtherCAT.
	off	Physical EtherCAT-CAT connection is not available
①	-	This LED is used for internal diagnostic purposes.

## 10 Safety engineering

### Introduction

## 10 Safety engineering

### 10.1 Introduction

With increasing automation, protection of persons against hazardous movements is becoming more important. Functional safety describes the measures needed by means of electrical or electronic equipment to reduce or remove danger caused by failures.

During normal operation, safety equipment prevents people accessing hazardous areas. In certain operating modes, e.g. set-up mode, work needs to be carried out in hazardous areas. In these situations the machine operator must be protected by integrated drive and control measures.

Drive-based safety provides the conditions in the controls and drives to optimise the safety functions. Planning and installation expenditure is reduced. In comparison to the use of standard safety engineering, drive-based safety increases machine functionality and availability.

#### **Integrated safety engineering**

##### **E70ACMxxxxx4xAxETx - Basic Safety - STO**

i700 controllers are available with drive-based safety.

The integrated safety system can be used for the protection of persons working on machines in accordance with the Machinery Directive.

The motion functions continue to be executed by the controller. The integrated safety system monitors the safe compliance with the limit values and provides the safe inputs. If monitored limit values are exceeded, the integrated safety system starts control functions directly in the controller according to EN 60204-1 to counteract possible errors.

The safety functions are suitable for applications according to IEC 61508 to SIL 3 and achieve a performance level (PL) e and the control category 4 according to EN ISO 13849-1.



## 10.2 Important notes

### Application as directed

The controllers that are equipped with safety engineering must not be modified by the user. This concerns the unauthorised exchange or removal of the safety engineering.



#### **Danger!**

##### **Danger to life through improper installation**

Improper installation of safety engineering systems can cause an uncontrolled starting action of the drives.

##### **Possible consequences:**

- ▶ Death or severe injuries

##### **Protective measures:**

- ▶ Safety engineering systems may only be installed and commissioned by qualified and skilled personnel.
- ▶ All control components (switches, relays, PLC, ...) and the control cabinet must comply with the requirements of EN ISO 13849-1 and EN ISO 138492. This includes i.a.:
  - Switches, relays with at least IP54 enclosure.
  - Control cabinet with at least IP54 enclosure.
  - Please refer to EN ISO 13849-1 and EN ISO 138492 for all further requirements.
- ▶ It is essential to use insulated wire end ferrules for wiring.
- ▶ All safety relevant cables outside the control cabinet must be protected, e.g. by means of a cable duct:
  - Ensure that no short circuits can occur.
  - For further measures see EN ISO 138492.
- ▶ If an external force acts upon the drive axes, additional brakes are required. Please observe that hanging loads are subject to the force of gravity!



#### **Danger!**

When the "safe torque off" (STO) function is used, an "emergency switching-off" according to EN 60204 is not possible without additional measures. There is no electrical isolation, no service switch or repair switch between motor and controller!

"Emergency switching-off" requires an electrical isolation, e.g. by a central mains contactor!

**During operation**

After the installation is completed, the operator must check the wiring of the safety function.

The functional test must be repeated at regular intervals. The time intervals to be selected depend on the application, the entire system and the corresponding risk analysis. The inspection interval should not exceed one year.

**Residual hazards**

In case of a short-circuit of two power transistors a residual movement of the motor of up to  $180^\circ$ /number of pole pairs may occur! (Example: 4-pole motor  $\Rightarrow$  residual movement max.  $180^\circ/2 = 90^\circ$ )

This residual movement must be considered in the risk analysis, e.g. safe torque off for main spindle drives.

**10.2.1 Hazard and risk analysis**

This documentation can only accentuate the need for hazard analysis. The user of the integrated safety system must read up on standards and the legal situation:

Before the launch of a machine, the manufacturer of the machine must conduct a hazard analysis according to Machinery Directive 2006/42/EC to determine the hazards associated with the application of the machine. The Machinery Directive refers to three basic principles for the highest possible level of safety:

- ▶ Hazard elimination / minimisation by the construction itself.
- ▶ Required protective measures must be taken against hazards which cannot be eliminated.
- ▶ Existing residual hazards must be documented and the user must be informed of them.

Detailed information on the hazard analysis procedure is provided in the DIN EN ISO 12100:2013-08 - "Safety of machinery - General principles for design, risk assessment and risk reduction". The results of the hazard analysis determine the category for safety-related control systems according to EN ISO 13849-1. Safety-oriented parts of the machine control must be compliant.

**10.2.2 Standards**

Safety regulations are confirmed by laws and other governmental guidelines and measures and the prevailing opinion among experts, e.g. by technical regulations.

The regulations and rules to be applied must be observed in accordance with the application.

### 10.2.3 Mission time

The mission time of the used component must be observed and complied with. When the mission time of a component has expired, the component must be taken out of service and replaced. Continued operation is not permitted!

The specified mission time starts at the date of manufacture. The date of manufacture is permanently stored in the component and can be read out via an object.

For the STO safety function of the i700 device series, no special examination is specified. Therefore, the mission time cannot be reset via an examination.

The proof test interval is the period after which a proof test to reveal undetected faults must be performed.

The proof test is a periodic examination to reveal hidden hazardous failures in a safety-related system so that - if necessary - a repair can bring the system back to an "as new" state or restore it as close as under practical considerations possible to this state (see DIN EN 61508-4).

## 10 Safety engineering

Acceptance  
Description

### 10.3 Acceptance

#### 10.3.1 Description

The machine manufacturer must check and prove the operability of the safety functions used.

##### Inspector

The machine manufacturer must authorise a person with expertise and knowledge of the safety functions to carry out the test.

##### Test report

The test result of every safety function must be documented and signed by the inspector.



##### Note!

If parameters of the safety functions are changed, the inspector must repeat the test and record the results in the test report.

##### Scope of test

A complete test comprises the following:

- ▶ Documenting the plant including the safety functions:
  - Creating an overview screen of the plant
  - Describing the plant
  - Describing the safety equipment
  - Documenting the safety functions used
- ▶ Checking the function of the safety functions used:
  - "Safe torque off" function, STO
- ▶ Preparing the test report:
  - Documenting the functional test
  - Checking the parameters
  - Signing the test report
- ▶ Preparing the appendix with test records:
  - Protocols from the plant
  - External recording

#### 10.3.2 Periodic inspections

The correct sequence of the safety-oriented functions must be checked in periodic inspections. The risk analysis or applicable regulations determine the time distances between the tests. The inspection interval should not exceed one year.

## 10.4 Certification

The certification of the safety system integrated in the controllers of the i700 series is based on the following test fundamentals:

- ▶ EN ISO 13849-1  
Safety of machinery - Safety-related parts of control systems - Part 1: General principles for design
- ▶ EN ISO 13849-2  
Safety of machinery - Safety-related parts of control systems - Part 2: Validation
- ▶ EN 60204-1  
Safety of machinery - Electrical equipment of machines - Part 1: General requirements
- ▶ IEC 61508, Part 1-7  
Functional safety of electrical/electronic/programmable electronic safety-related systems
- ▶ EN 61800-3  
Adjustable speed electrical power drive systems - Part 3: EMC requirements and specific test methods
- ▶ EN 61800-5-1  
Adjustable speed electrical power drive systems - Part 5-1: Safety requirements - Electrical, thermal and energy
- ▶ EN 61800-5-2  
Adjustable speed electrical power drive systems - Part 5-2: Safety requirements - Functional
- ▶ EN 62061  
Safety of machinery - Functional safety of safety-related electrical, electronic and programmable electronic control systems



Declarations of conformity and certificates can be found on the internet at: <http://www.Lenze.com> and on the product CD.

**10.5 Basics for safety sensors**

The components used must comply with the control category required for the application.

**Passive sensors**

Passive sensors are two-channel switching elements with contacts. The connecting cables and the sensor function must be monitored.

The contacts must switch simultaneously (equivalently). Nevertheless, safety functions will be activated as soon as at least one channel is switched.

The switches must be wired according to the closed-circuit principle.

Examples of passive sensors:

- ▶ Door contact switch
- ▶ Emergency stop control units

**Active sensors**

Active sensors are units with 2-channel semiconductor outputs (OSSD outputs). With the integrated safety system of this device series, test pulses  $< 1$  ms for monitoring the outputs and cables are permissible. The maximally permissible connection capacity of the outputs is to be observed. Active sensors are wired directly to the terminals of the integrated safety system. Monitoring for cross or short circuits must be carried out by the active sensor.

P/M-switching sensors switch the positive and negative cable or the signal and ground wire of a sensor signal.

The outputs must switch simultaneously (equivalently). Nevertheless, safety functions will be activated as soon as at least one channel is switched. Active triggering of only one channel indicates faulty sensors or impermissible wiring.

Examples of active sensors:

- ▶ Lightgrid
- ▶ Laser scanner
- ▶ Control systems

## 10.6 Basic Safety - STO

### E70ACMxxxxx4xAxETx - Basic Safety - STO

#### 10.6.1 Mode of operation

With the integrated safety system, product key: A, the following safety function can be used:

- ▶ **Safe Torque Off (STO)**

If requested, the safe disconnection of the drive is achieved through:

- ▶ Directly connected active sensors
- ▶ Passive sensors connected to a safety switching device

The safety functions are suitable for applications according to IEC 61508 to SIL 3 and achieve a performance level (PL) e and the control category 4 according to EN ISO 13849-1.



#### **Danger!**

If the request for the safety function is cancelled, the drive will restart automatically.

You must provide external measures which ensure that the drive only restarts after a confirmation (EN 60204).

The transmission of the pulse width modulation is safely switched (off) by the safety unit. After this, the power drivers do not generate a rotating field. The motor is safely switched to torqueless operation (STO).

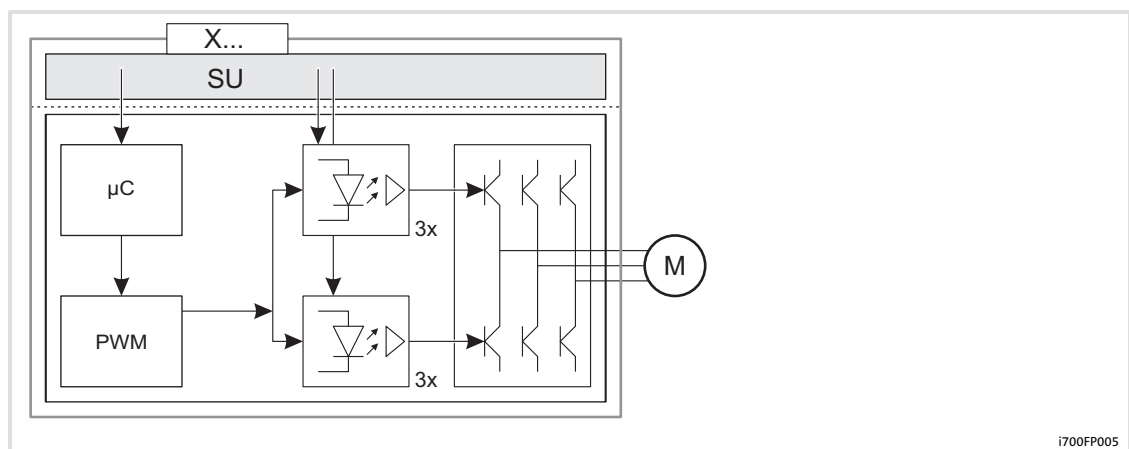

Fig. 10-1 Operating principle of safety unit

SU	Safety unit
X...	Control terminals of the safety unit
µC	Microcontroller
PWM	Pulse Width Modulation
M	Motor

#### **Safety status**

If the controller is switched off by the safety system, the "STO is not active" status in the status word changes from 1: HIGH to 0: LOW (object 0x6041/0x6841, bit 15).

## 10.6.2 Technical data

## Supply

The inputs are isolated and designed for a low-voltage supply through a safely separated power supply unit (SELV/PELV) of 24 V DC. P/N switching input signals and test pulses  $\leq 1$  ms are permissible.

Active sensors are directly wired to the X1 terminal strip.

Passive sensors are wired to the X1 terminal strip via a switching device. The switching device must comply with the required control category of the application.

There is no monitoring for short circuits.

Terminal X1	Specification	[Unit]	min.	typ.	max.
	The input channels comply with the IEC 61131-2 standard, type 1.				
SIA, SIB	Low signal	V	-3	0	5
	High signal	V	15	24	30
	Input capacitance at switch-off	nF		3	
	Input delay (tolerated test pulse)	ms			1
	Switch-off time	ms		5	
	Running time	ms		1	
	Input current	mA	2		15
	Input capacitance at switch-on	nF		100	
	Test pulses permissible at intervals of	ms	10		
	Polarity reversal protection	When polarity is reversed: no function and no destruction.			
GS	Ground for SIA/SIB				

## Truth table

Safe input / channel		Controller	
SIA	SIB	Description of device status	Enable
0	0	"Safe torque off" activated	0
0	1		0
1	0		0
1	1	Drive active	1



**Safety-related parameters acc.to IEC 61508-1 to -7 and IEC 62061**

Specification	Value	Comment
Safety Integrity Level	SIL 3	
PFH [1/h]	7.79 E-10	0.78 % of SIL 3
PFD	6.82 E-5	6.8 % of SIL 3 after T = 20 years
Proof test interval	20 years	Mission time

**Safety-related parameters acc. to EN ISO 13849-1**

Specification	Value	Comment
Performance Level	e	
Category	4	
MTTF <sub>d</sub>	high	71285 years
Diagnostic coverage DC	high	99 %

**Note on safety-related parameters**

Source of failure rates	SN 29500	As far as values from the component manufacturers were not available
Average max. ambient temperature	40 °C	
General assumption that 50 % of the failures of a component are hazardous failures	$\lambda_d = 0.5 \lambda$ , MTTF <sub>d</sub> = 2 MTTF	As far as other information was not available

10.6.3

Electrical installation

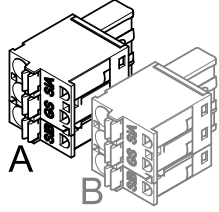
X1	Labelling	Description	
 i700P00x	SIA	Safe input, channel A	On double axis devices, there are two of these connections. For the assignment to the axes, the designations "A" / "B" are used. Independently of this, the two-channel safe input is always provided with the channels A and B.
	GS	Reference potential GND	
	SIB	Safe input, channel B	

	Conductor cross-section		Tightening torque		
	[mm <sup>2</sup> ]	[AWG]	[Nm]	[lb-in]	
flexible	0.2 ... 2.5	24 ... 12	-	-	3.5 x 0.6
Rigid	0.2 ... 2.5	24 ... 12	-	-	3.5 x 0.6

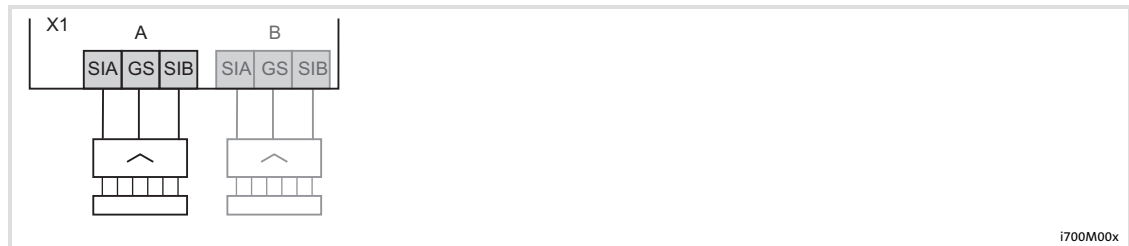

Fig. 14 Wiring of X1

- |     |   |
|-----|---|
| X1  | <b>Connection of integrated safety system</b> |
| A   | 1-axis module                                 |
| B   | Additionally for 2-axis module                |
| SIA | Safety system input, channel A                |
| SIB | Safety system input, channel B                |
| GS  | Reference potential GND                       |



**Note!**

To avoid interchanging of the plug-in terminals - especially in the case of double axis devices -, the plug-in terminals can be provided with coding pins. Alternatively, we recommend to label the terminals clearly in order to enable the correct assignment of plugs and sockets.



**Note!**

If integrated safety is not to be used for an axis, the safe inputs SIA and SIB of the axis must be fixedly assigned with "HIGH" potential (24 V). The wiring should not give the impression of connected safety sensors, or should be provided with adequate labelling.

## 11 Accessories (overview)



### Note!

You can find additional information on the accessories in the catalogue to this product series.

### 11.1 Overview

Coordinated accessories for i700:

- ▶ Mains chokes
- ▶ RFI filters and mains filters
- ▶ Brake resistors
- ▶ 24-V power supply units
- ▶ Terminals for plug-in connections
- ▶ DC terminal
- ▶ Mounting frame for push-through technique
- ▶ EMC shield mounting kits

## 11.2 Mains chokes

Mains chokes:

Inductances for damping conducted harmonic interferences which may arise from reloading the DC bus and the switching frequency of the inverter.

## Assignment of mains chokes

Mains choke	Power supply module
EZAELN3025B122	E70ACPSx0304x
EZAELN3050B591	E70ACPSx0604x

## Technical data

	$I_N$ [A]	L [mH]	$P_V$ [W]
EZAELN3025B122	25	1.18	72.0
EZAELN3050B591	50	0.59	144

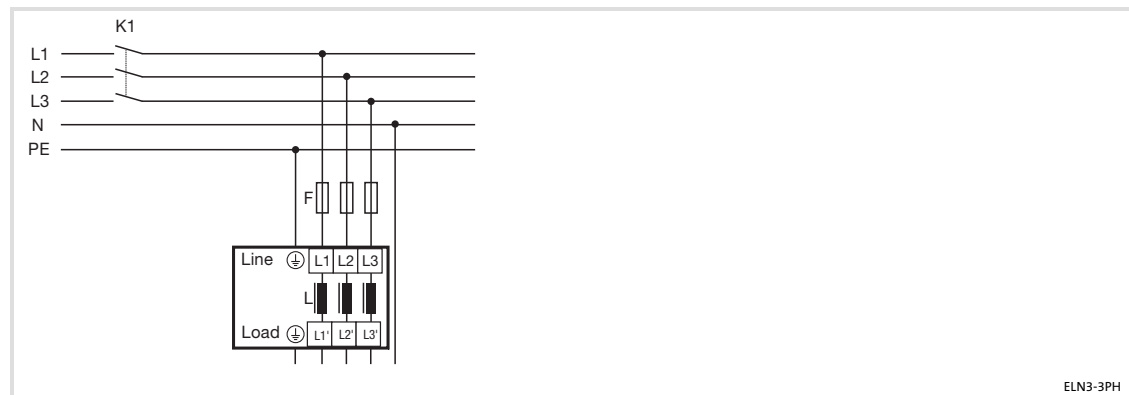

Fig. 11-1 Basic circuit diagram

Consider the following criteria when using mains chokes:

- ▶ Mains chokes are always required if all interconnected devices are operated with rated current and speed.
- ▶ Mains chokes are not required if the power of the entire network is less than 50 % of the added continuous powers of all interconnected devices (= standard case).

$$\Sigma P_a \leq 0.5 \cdot \Sigma P_{ar}$$

$\Sigma P_a$

Sum of the average output power of the axes in the network  
Medium mains power, depending on the "in motor mode/in generator mode" operating status, motor current, motor speed and device losses

$\Sigma P_{ar}$

Sum of the rated power of the axes in the network

- ▶ The use of mains chokes for complying with the EMC category C3 has to be assessed separately (📖 122).

Notwithstanding the above, consider the advantages when using mains chokes:

- ▶ Increase of the available mains power by approx. 50 %
- ▶ Reduction of the transient mains current at short-term power-off
- ▶ Reduction of the mains current to approx. 2/3 of the value without mains choke  
This increases the service life of the DC bus capacitor considerably. Regarding the service life, the i700 devices are dimensioned for 40.000 h.

# 11 Accessories (overview)

## RFI filter/mains filter

### 11.3 RFI filter/mains filter

Advantages by the use of filters:

- ▶ Compliance with EMC requirements
- ▶ Reduction of the current load
- ▶ Positive effects on the service life of the controllers possible
  - Strong reliability
  - Reduction of the failure rate
- ▶ Operation on 300 mA earth-leakage circuit breakers (type B) for device sizes 1 ... 3 (bis 24 A/11 kW) is enabled. For this purpose, observe the device number and motor cable lengths according to "Compliance with the EMC category C2 (residential areas)" (123)

Mains filters:

Mains filters reduce the conducted interference emission into the mains for compliance with the requirements acc. to EN 61800-3. Mains filters are a combination of mains choke and RFI filter in one housing.

	Voltage [V]	Freq. [Hz]	Current [A] ① max. +45° C	Current [A] ① max. +55° C	Number of phases
E94AZMP0084	400/480	50/60	8/8	6/6	3
E94AZMP0294	400/480	50/60	29/29	21.8/21.8	3
E94AZMP0824	400/480	50/60	82/82	61/61	3

① Temperature in the control cabinet

RFI filters:

RFI filters are capacitive accessories for compliance with the requirements acc. to EN 61800-3 for conducted interference emission. RFI filters can be directly connected upstream of the power supply modules. RFI filters are also called EMC filters.

	Voltage [V]	Freq. [Hz]	Current [A] ① max. +45° C	Current [A] ① max. +55° C	Number of phases
E94AZRP0084	400/480	50/60	8/8	6/6	3
E94AZRP0294	400/480	50/60	29/29	21.8/21.8	3
E94AZRP0824	400/480	50/60	82/82	61/61	3

① Temperature in the control cabinet

11.4 External brake resistors

Power supply module	Brake resistor	Resistance R [ $\Omega$ ]	Continuous power P [W]	Quantity of heat QB [kWs]
E70ACPSx0304x	ERBP027R200W	27	200	30
	ERBS027R600W	27	600	90
	ERBS027R01K2	27	1200	180
E70ACPSx0604x	2    ERBP018R300W	9	600	60
	ERBP018R300W	18	300	30
	ERBG012R01K9	12	1900	285
	ERBG012R05K2	12	5200	780

# 11 Accessories (overview)

## Power supply units

### 11.5 Power supply units

External power supply units are available for supplying the control electronic with an 24-V supply.

Type	Mains		Secondary	
	$V_{LN}$ [V]	$I_{LN}$ [A]	$V_{DC}$ [V]	$I_{DC}$ [A]
EZV1200-000	230 (1/N/PE AC)	0.8	24 (22.5 ... 28.5)	5
EZV2400-000		1.2		10
EZV4800-000		2.3		20
EZV1200-001	400 (3/PE AC)	0.3		5
EZV2400-001		0.6		10
EZV4800-001		1.0		20

EZVxxx-001, alternative  $V_{LN}$ : 450 ... 800 V, 2/PE DC,  EDKZV1200



11.6 Terminals

To the devices of the i700 servo inverter product series, coordinated terminal accessory kits are assigned. These kits must be ordered separately.

		Accessory kits	
E70ACMxx0054xA1xxx		E70AZEVK001	
E70ACMxx0104xA1xxx			
E70ACMxx0204xA1xxx			
E70ACMxx0324xA1xxx		E70AZEVK003	
E70ACMxx0484xA1xxx			
E70ACMxx0644xA1xxx			
E70ACMxx0054xA2xxx		E70AZEVK002	
E70ACMxx0104xA2xxx			
E70ACMxx0204xA2xxx		E70AZEVK004	
E70ACMxx0324xA2xxx			
E70ACPSx0304x	E70AZEVK005	E70AZEVK007 (for parallel connection)	
E70ACPSx0604x	E70AZEVK006		

①		Kit E70AZEVK...			
		...001	...002	...003	...004
X1	SIB, GS, SIA	1 (A)	2 (A, B)	1 (A)	2 (A, B)
X2	GD, DI2, DI1	1 (A)	2 (A, B)	1 (A)	2 (A, B)
X3	GE, 24E	1	1	1	1
X4/X5	EtherCAT	1	1	1	1
X105	GE, 24E	1	1	1	1
X106	BD2, BD1	1 (A)	2 (A, B)	1 (A)	2 (A, B)
X108	U, V, W, PE	1 (A), 4 mm <sup>2</sup>	1 (A), 4 mm <sup>2</sup>	1 (A), 16 mm <sup>2</sup>	1 (A), 4 mm <sup>2</sup>
X107	U, V, W, PE	-	1 (B), 4 mm <sup>2</sup>	-	1 (B), 4 mm <sup>2</sup>
①	⚡	1 (↔ 50)	1 (↔ 50)	1 (↔ 100)	1 (↔ 100)
②	2	1	2		
③	3	-	-	1	2
④	-	1	1	1	1

i		Kit E70AZEVK...		
		...005	...006	...007
X100	L3, L2, L1, PE	1	1	-
X20 A	DI3, DI2, DI1	1 (A)	1 (A)	-
X20 B	GD, DO2, DO1	1 (B)	1 (B)	-
X21	GE, 24E	1	1	-
X103	PE, Rb2, Rb1	1	1	-
X101, X102	+UG, -UG	-	-	2
PE	⊕	-	-	1
①	↔	1 (↔ 50)	1 (↔ 100)	-
②	2	1	-	-
③	3	-	1	-
④	-	1	1	-

E70AZEVK001

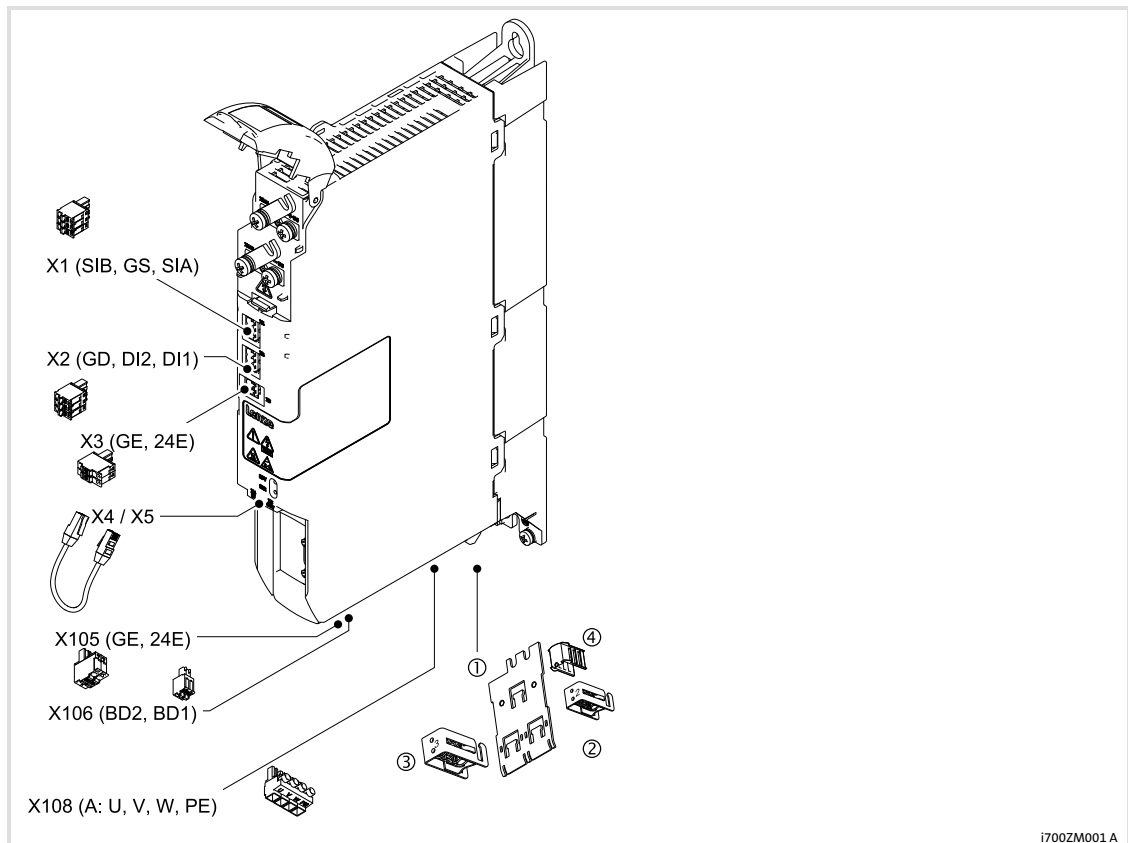

E70AZEVK002

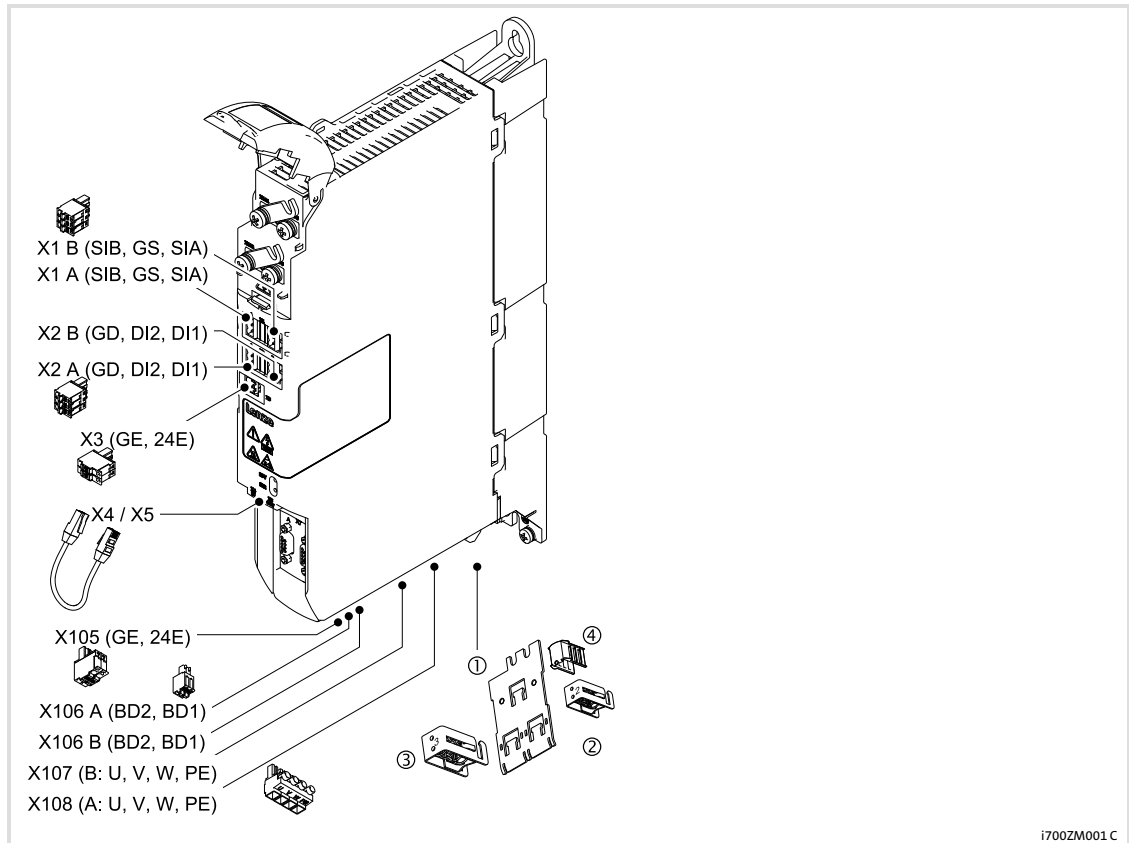

E70AZEVK003

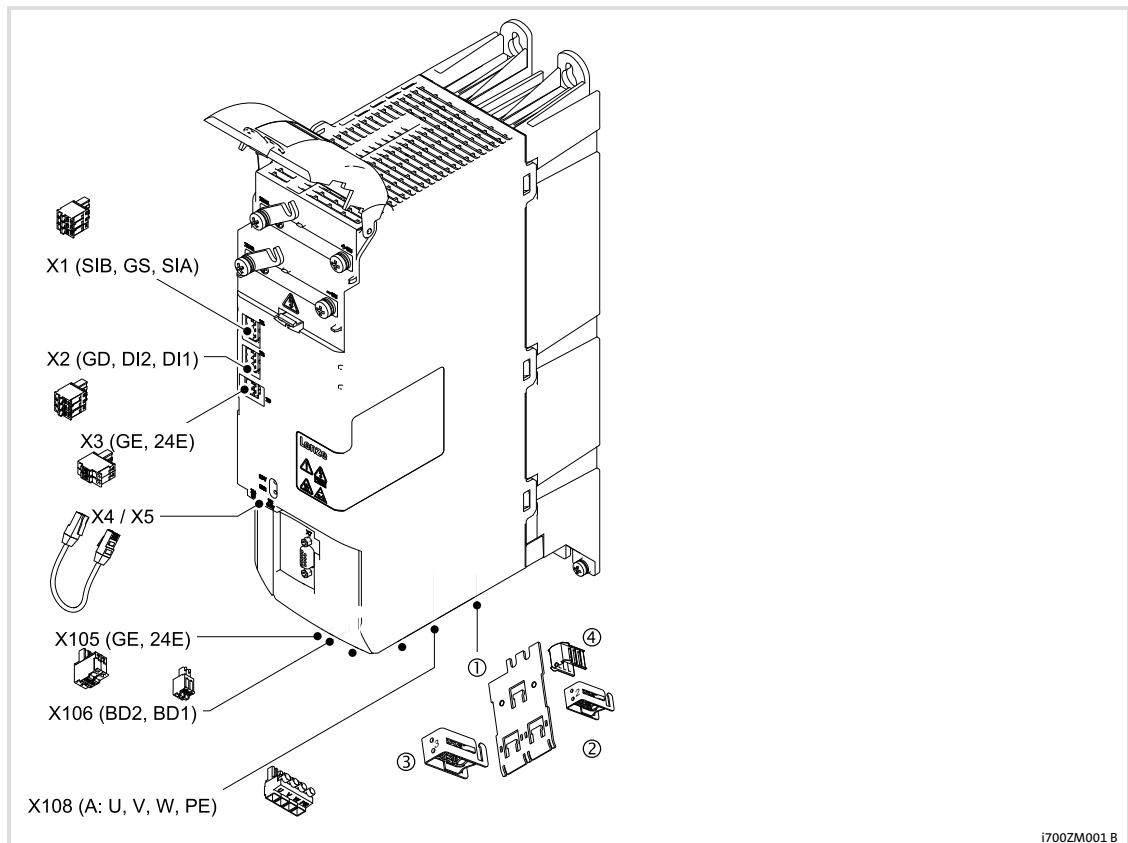

i700ZM001 B

E70AZEVK004

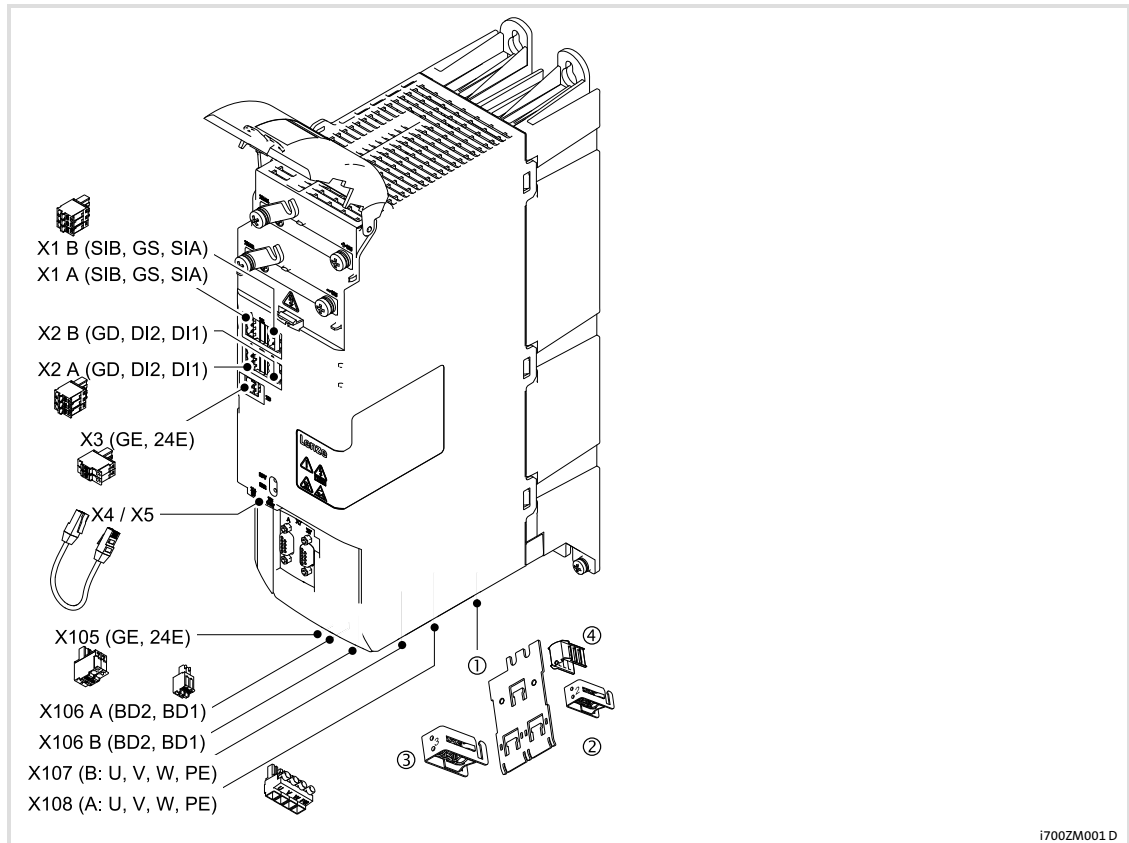

E70AZEVK005

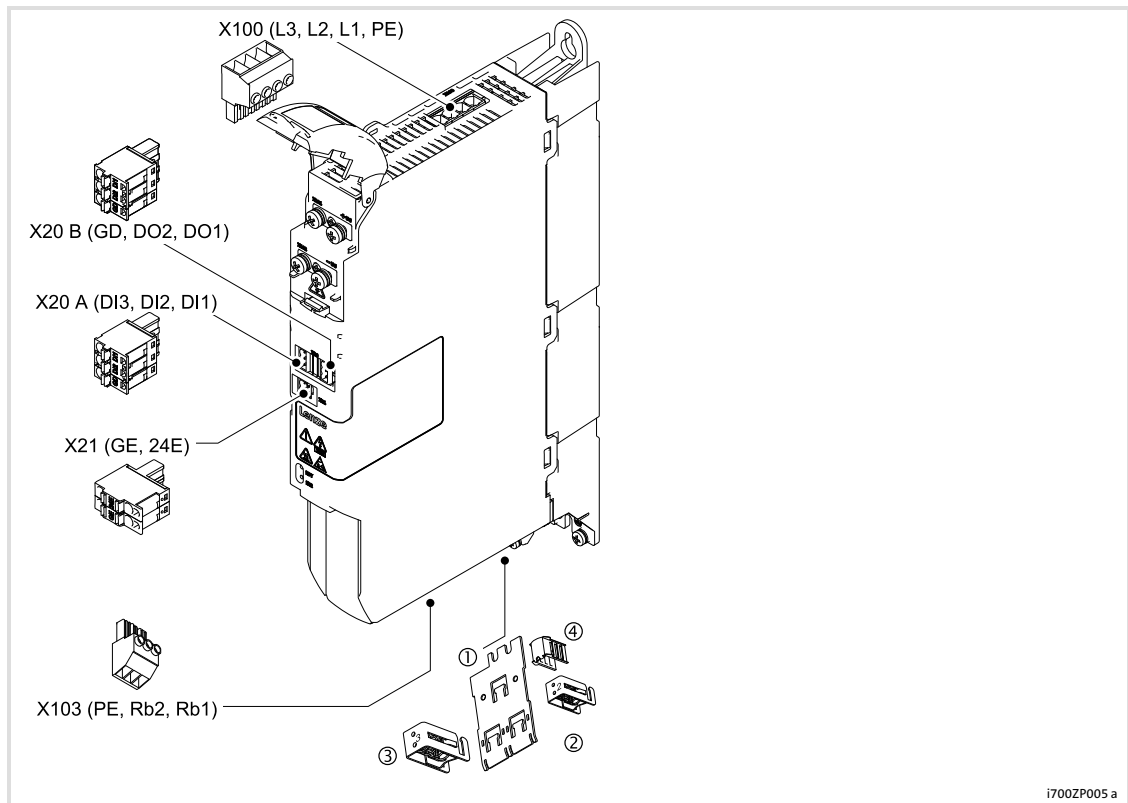

E70AZEVK006

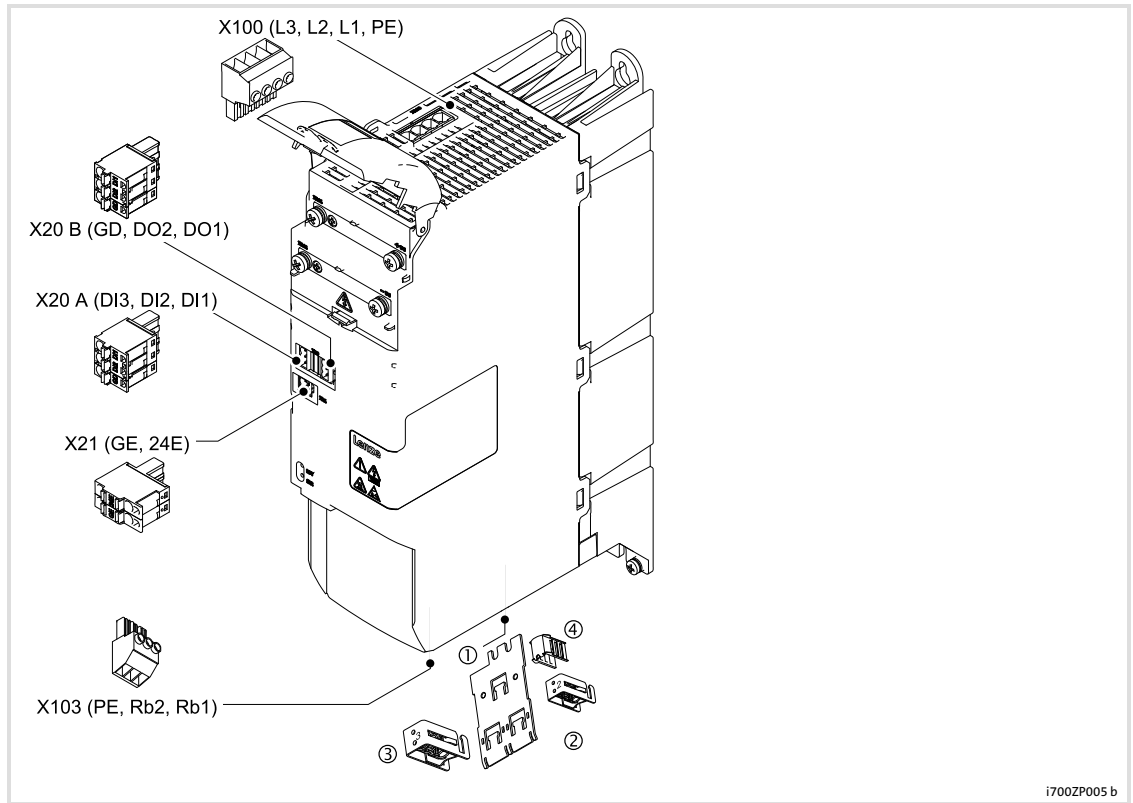



**E70AZEVK007**

In order to wire the +UG and -UG connections, the "Power Supply Kit UG/PE", designation E70AZEVK007, is required. In addition to the connectors for UG, it also contains a connector for an optimum PE connection.

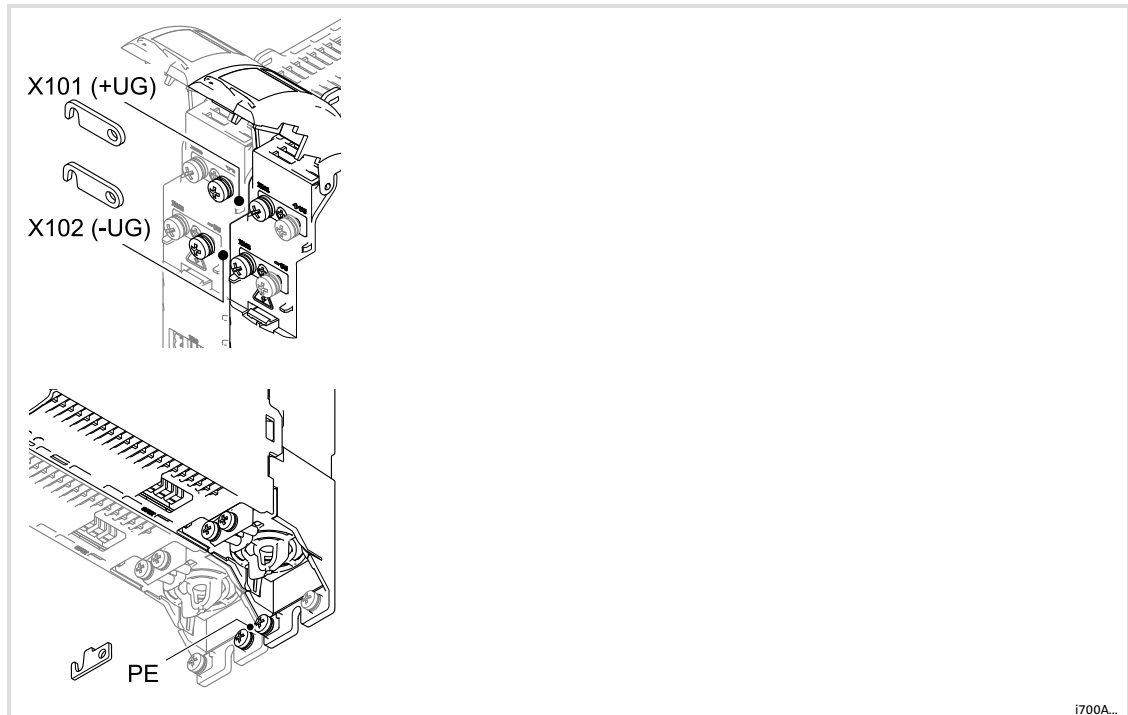

i700A...

**11.7****Components for operation in the DC-bus connection**

The E70AZEVE001 DC terminal is adapted to the i700 series.

By means of the DC terminal, a connection to the busbar system of the DC bus can be established using a cable.

- ▶ Distribution of the installation to several rows, groups, or control cabinets.
- ▶ Energy exchange, e.g. with external DC-energy storage mechanisms.
- ▶ Provides for cable cross-sections  $\leq 35 \text{ mm}^2$  or  $2 \times \leq 25 \text{ mm}^2$ .
- ▶ Ensures protection against contact.
- ▶ Mounting can be carried out on the left or right.

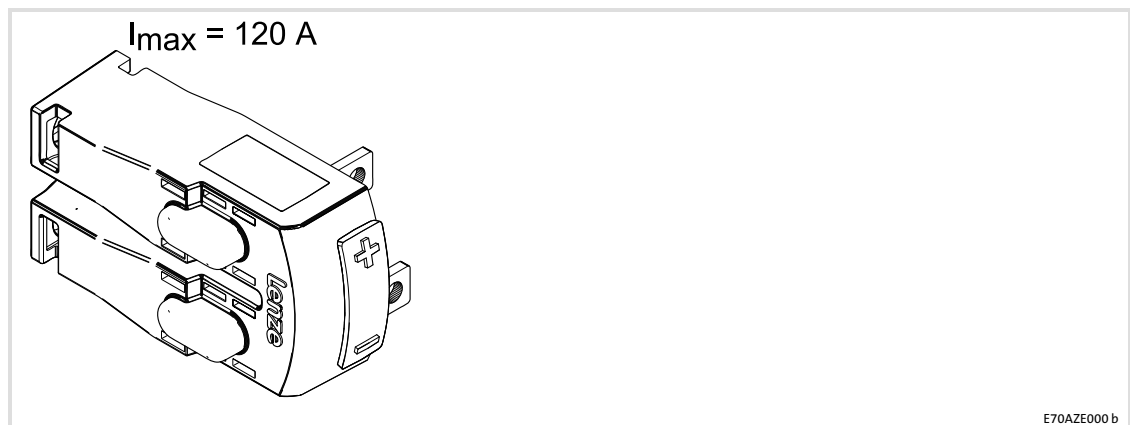

### 11.8 Installation material for the push-through technique

The E70AZMBHM00x mounting frames make it easier to stabilise and seal the cutouts when the push-through technique is applied.

- ▶ Threads for frames and devices are integrated.
- ▶ The frames can be mounted beforehand without the devices.
- ▶ E70AZMBHM001 for a width of 50 mm, VPE: 5 items
- ▶ E70AZMBHM002 for a width of 100 mm, VPE: 5 items

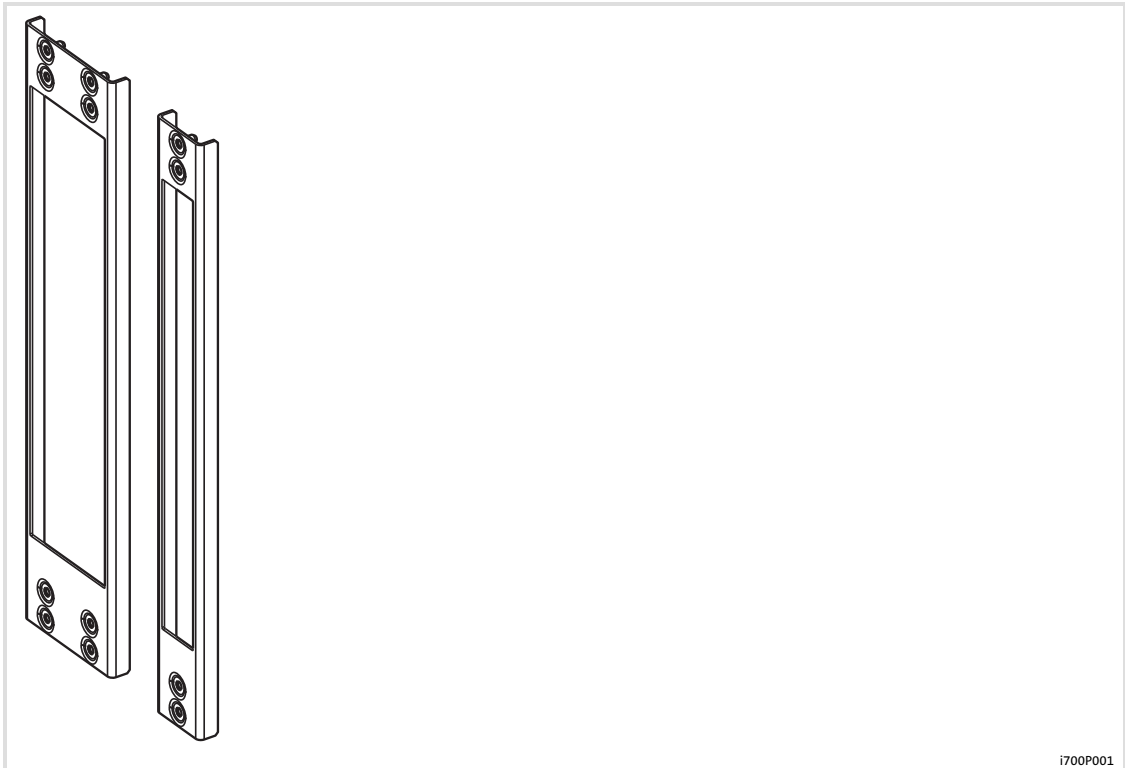

i700P001

# 11 Accessories (overview)

EMC accessories  
Shield mounting

## 11.9 EMC accessories

### 11.9.1 Shield mounting

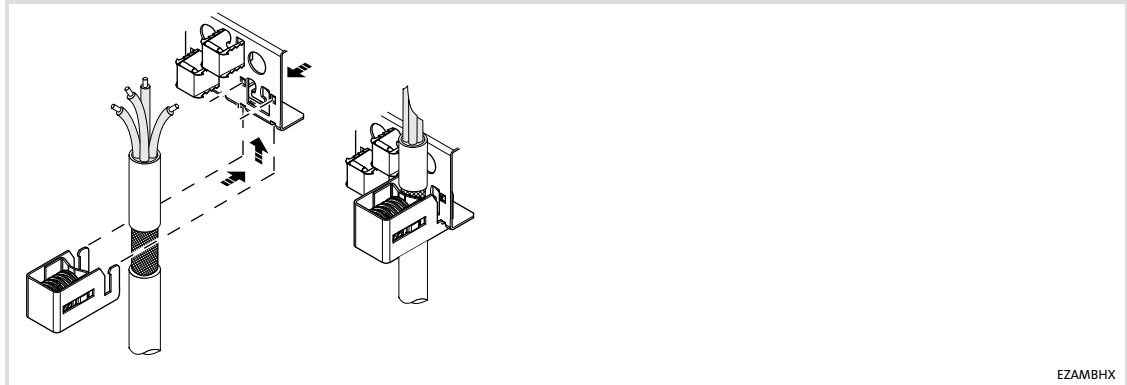

EZAMBHX

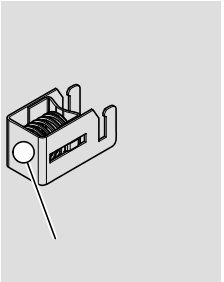
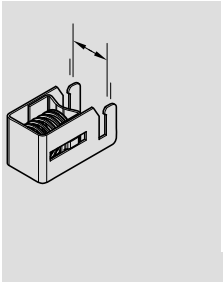
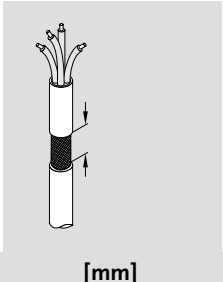
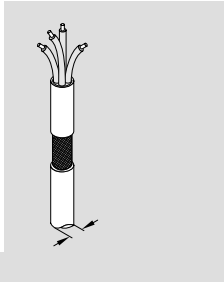
				
			[mm]	
EZAMBHXM006 (< E94AZJS003)	2	18	20	4 ... 15
EZAMBHXM003 (< E94AZJS007)	3	19	30	10 ... 20
EZAMBHXM004 (< E94AZJS024)	4	27	30	15 ... 28
EZAMBHXM005	5	37	35	20 ... 37

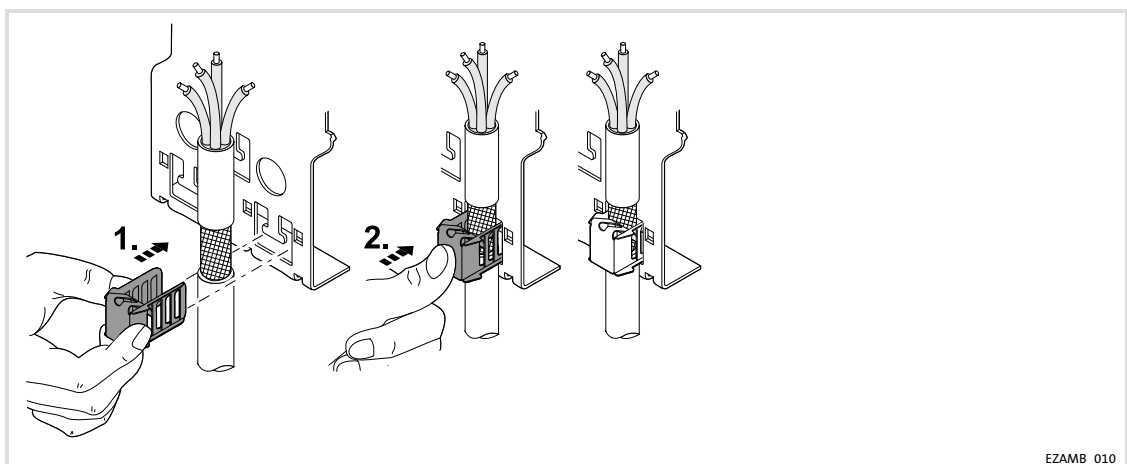

EZAMB\_010

EZAMBHXM007		20 mm		4 ... 10 mm
-------------	---	-------	--	-------------

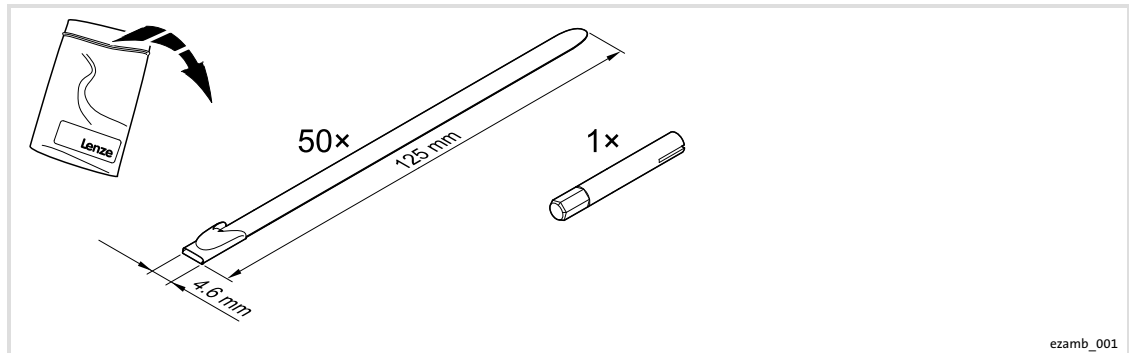

ezamb\_001

		
EZAMBKBM	> 10 mm	8 ... 30 mm

**12**      **Appendix**

**12.1**      **Total index**

**A**

Accessories, 139

**B**

Basic Safety - STO, 135

Braking operation, in a drive system, 121

**C**

Cable, for the motor connection, 96

**Cables**

- cross-sections, 37

- fuses, 37

"Cold Plate", requirements for the cooler, 71

Commissioning, 125

- before switching on, 125

Compensation equipment, interactions with, 88

Configuration, Display functions, 126

Contactors, in the motor cable, 19

**D**

DC bus, connection to the, 49, 61

DC supply, 95

DC-bus connection, Braking in, 121

DC-bus operation, 110

- Conditions, 111

- DC bus, 10

- DC-voltage level, 10

- Multi-axis controllers, 10

- Power supply module, 10

- Regenerative power supply module, 10

- Several drives, 110

- Single-axis controllers, 10

Definition of notes used, 12

Definitions, Terms, 9, 110

Device features, 20

Device protection, 18, 86

Diagnostics, 126

Display functions, 126

dissipation of the increased power loss, 79

**E**

EC-Dual-Use Regulation, 21

Electrical installation, 86, 138

**EMC**

- Accessories, 156

- filter assignment, 123

- in DC-bus operation, 122

- what to do in case of interferences, 100

**EMC category**

- C2, 123

- C3, 122

EMC filters, disconnecting from PE, 101

EN 61000-3-2, 28

Export control, EC-Dual-Use Regulation, 21

External voltage supply, 46, 54

**F**

Free space, 30

Fuses, 37

- operation with rated power, 400 V (UL), 37

**H**

Harmonic currents, limitation according to EN 61000-3-2, 28

Hazard analysis, 130

**I**

Identification, 24

**Installation**

- electrical, 138

- Mechanical, Cold plate technique, 71

Installation material, push-through technique, 155

Installation, electrical, 86

Installation, mechanical, 66

Interactions with compensation equipment, 88

Interferences, eliminating EMC interferences, 100

**IT system**

- measures, 101

- separating the EMC filter from PE, 101

**L**

LED status displays, 127

**M**

Mains chokes, 140

Mains connection, 95

Mains filter, 142

Mechanical installation, 66

- "cold plate" technology, requirements for the cooler, 71

- Cold plate technique, 71

Mission time, 131

Motor cable, 96

- capacitance per unit length, 30

- contactors in the, 19

- requirements, 30

Motor connection, 64

Motor end, switching on the, 19

Motor protection, 19

Mounting position, 30

**N**

Nameplate, 24

Network of several drives, Basic dimensioning, 118

Noise emission, 28

Noise immunity, 28

Notes, definition, 12

**O**

Operation, Overcurrent, 22

Output currents, Switching frequency-dependent, 40

Overspeeds, 19

Overview

- Accessories, 139

- devices, 22

- terminals, 45

**P**

Parameter set transfer, 19

Product description, 20

Proof test interval, 131

Protection of persons, 18

Push-through technique, installation material, 155

**R**

Requirements, motor cable, 30

Residual hazards, 18, 130

RFI filter, 142

Risk analysis, 130

**S**

Safety, safety engineering, 128

Safety engineering, 128

- application as directed, 129

- Certification, 133

Safety functions, safety instructions, during operation, 130

Safety instructions, 13

- definition, 12

- during operation, 130

- layout, 12

Safety system, technical data, 136

Sensors, basics, 134

Separating the heatsink losses, 79

Shield mounting, 156

Status displays, 127

Supply conditions

- axis modules, 30

- general, 30

- motors, 30

- power supply modules, 30

Supply voltage, 24 V external, 31

Switch-on, check before switching on, 125

Switching on the motor side, 19

**T**

Technical data, 27

- safety system, 136

Terminals, 45, 145

Terms

- Definitions, 110

- definitions, 9

Total index, 158

Type code, finding, 24

**U**

Use in IT systems, 101

**V**

Validity, documentation, 7

Voltage supply: external, 46, 54

**W**

Waste disposal, 16

**Wiring**

- in the control cabinet, 97

- outside of the control cabinet, 99

- X1, 138

- X100, 48

- X103, 50

- X105, 62

- X107, 64

- X108, 64

- X2, 53

- X20, 47, 121

- X21, 46

- X3, 54

wiring, X106, 63







© 08/2018

Lenze Automation GmbH  
Postfach 10 13 52, 31763 Hameln  
Hans-Lenze-Str. 1, 31855 Aerzen  
GERMANY  
HR Hannover B 205381



+49 5154 82-0



+49 5154 82-2800



lenze@lenze.com



www.lenze.com

Service

Lenze Service GmbH  
Breslauer Straße 3, 32699 Extertal

GERMANY



008000 2446877 (24 h helpline)



+49 5154 82-1112



service@lenze.com

EDS700ACBA ■ 13528287 ■ EN ■ 5.1 ■ TD15

10 9 8 7 6 5 4 3 2 1